

PRACTICAL GUIDE

Low-voltage power systems

Protection against overvoltages

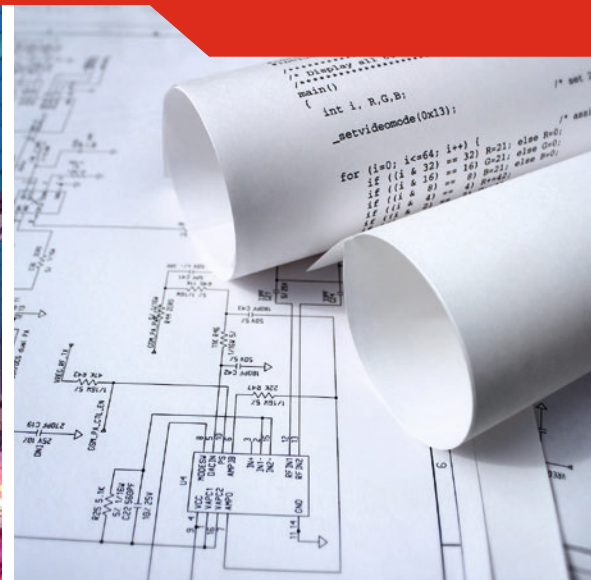

Introduction

Since the 1960s, the purely technical term EMC (electromagnetic compatibility) has become a term comprising not only safety for appliances and components, but in particular, for their users. Apart from others, it refers to the resistance of devices and equipment to all forms of electromagnetic disturbance, including impulse overvoltage and high frequency disturbance. It is thus the suppliers who must increase the resistance of systems today. A correctly designed and installed system of surge protective devices and SALTEK® filters can satisfy even the most demanding requirements for the safety of equipment in terms of electromagnetic compatibility.

The current standard of technology offers good protection for electronic and electrical equipment against the effects of dangerous impulse overvoltage, i.e., surge arresters. Equipment can be protected not only against the effects of a destructive impulse that features great energy, but also against the effects of high frequency disturbances. Unprotected electrical wiring, computer and data networks always pose a huge risk for their users. Installing overvoltage protection devices therefore prevents possible damage. The price of surge arresters is only a tiny part of the cost expended on protected equipment and a negligible amount compared to the potential damage resulting from a failure or destruction of the technological equipment followed by financial losses.

SALTEK surge arresters comply to Czech and international standards.



Electronic components damaged by overvoltage

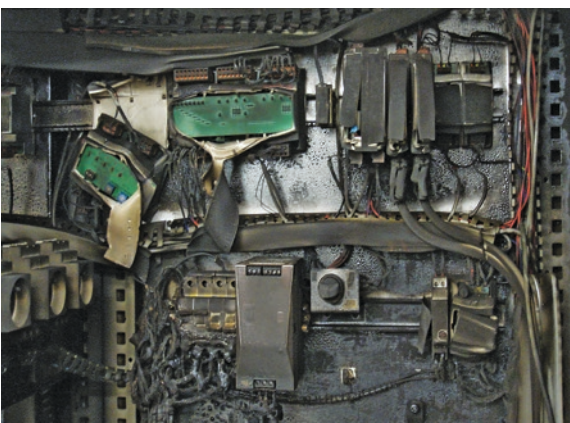

Overvoltage

Overvoltage types

Basically, overvoltage can be classed according to its duration.

Transient overvoltage – short-term changes in voltage:

overvoltage that lasts a short time not exceeding several thousandths of a second, oscillating or non-oscillating, usually highly damped, in hundreds of microseconds (see Fig. 1a) – such overvoltage **can be successfully eliminated** using an SPD (Surge Protective Device).

Temporary overvoltage – long-term changes in voltage:

overvoltage with industrial frequency of oscillation and a relatively long duration

- in milliseconds or less (see Fig. 1b)
- such overvoltage **cannot be eliminated** by means of an SPD.

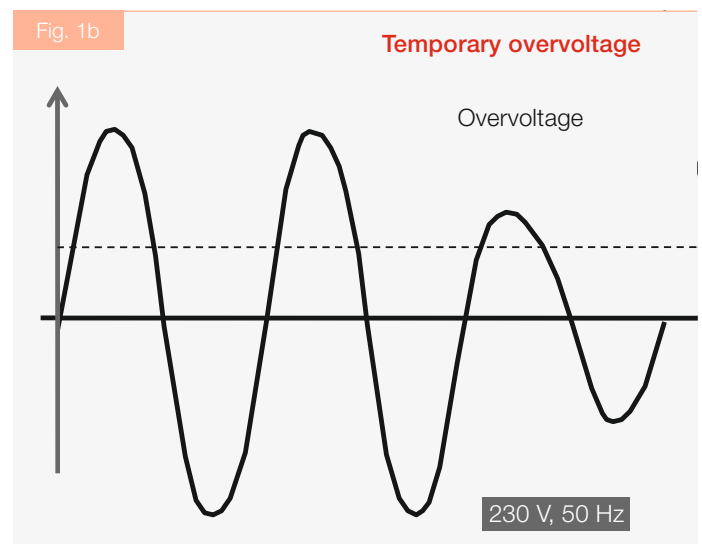
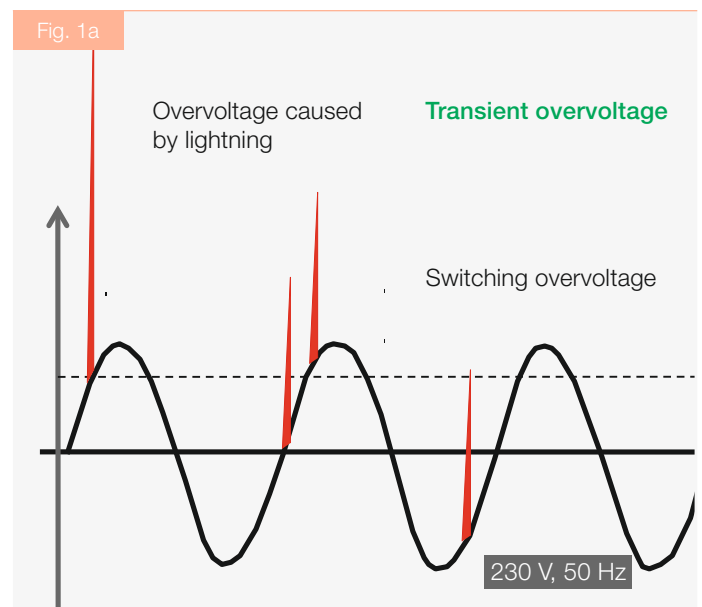

Short-term changes in voltage, i.e. transient overvoltage can be classed in several groups according to the origin:

- differential mode of overvoltage:** overvoltage between live conductors (L1-L2, L-N with LV supply, a-b with telecommunications...), such overvoltage occurs as a result of technological events – e.g. switching of non-linear loads (motors, refrigerators,...). These are particularly dangerous for electronic equipment, sensitive hardware-like control systems, computers and their software utilities, etc. (see Fig. 2)
- common mode of overvoltage:** overvoltage between the neutral conductor and earthing conductor (L-PE, N-PE in LV, a/b-PE in telecommunications...) that results from atmospheric events – a lightning strike. Such overvoltages are particularly dangerous for technological equipment, the frame of which is earthed (insulation breakdown). (see Fig. 3)

An SPD in the supply network will be selected according to the type of respective overvoltage.

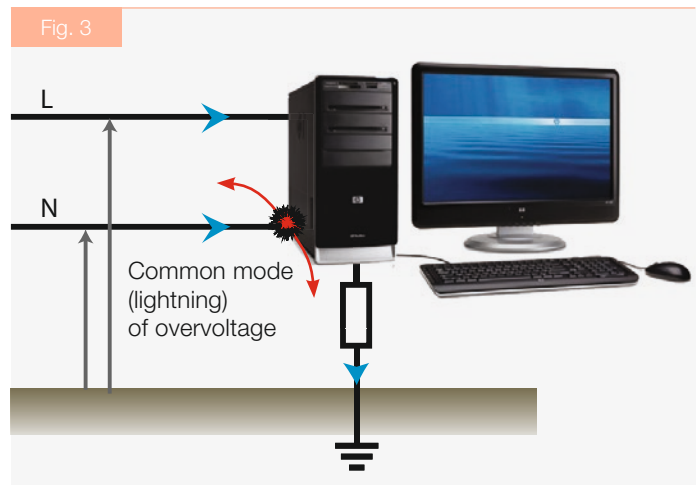
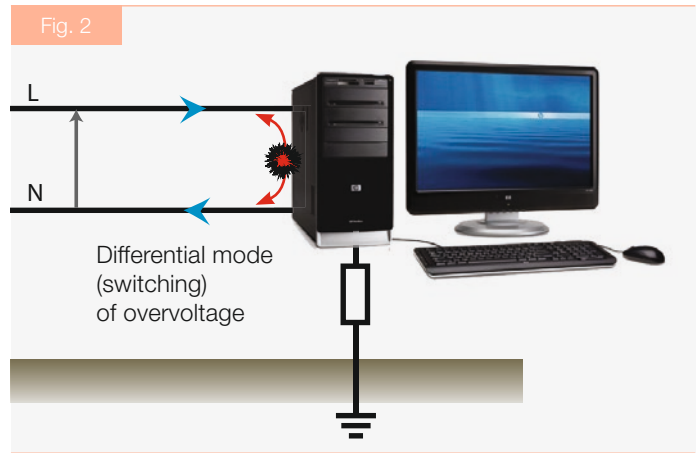

Parameters of (current) impulse

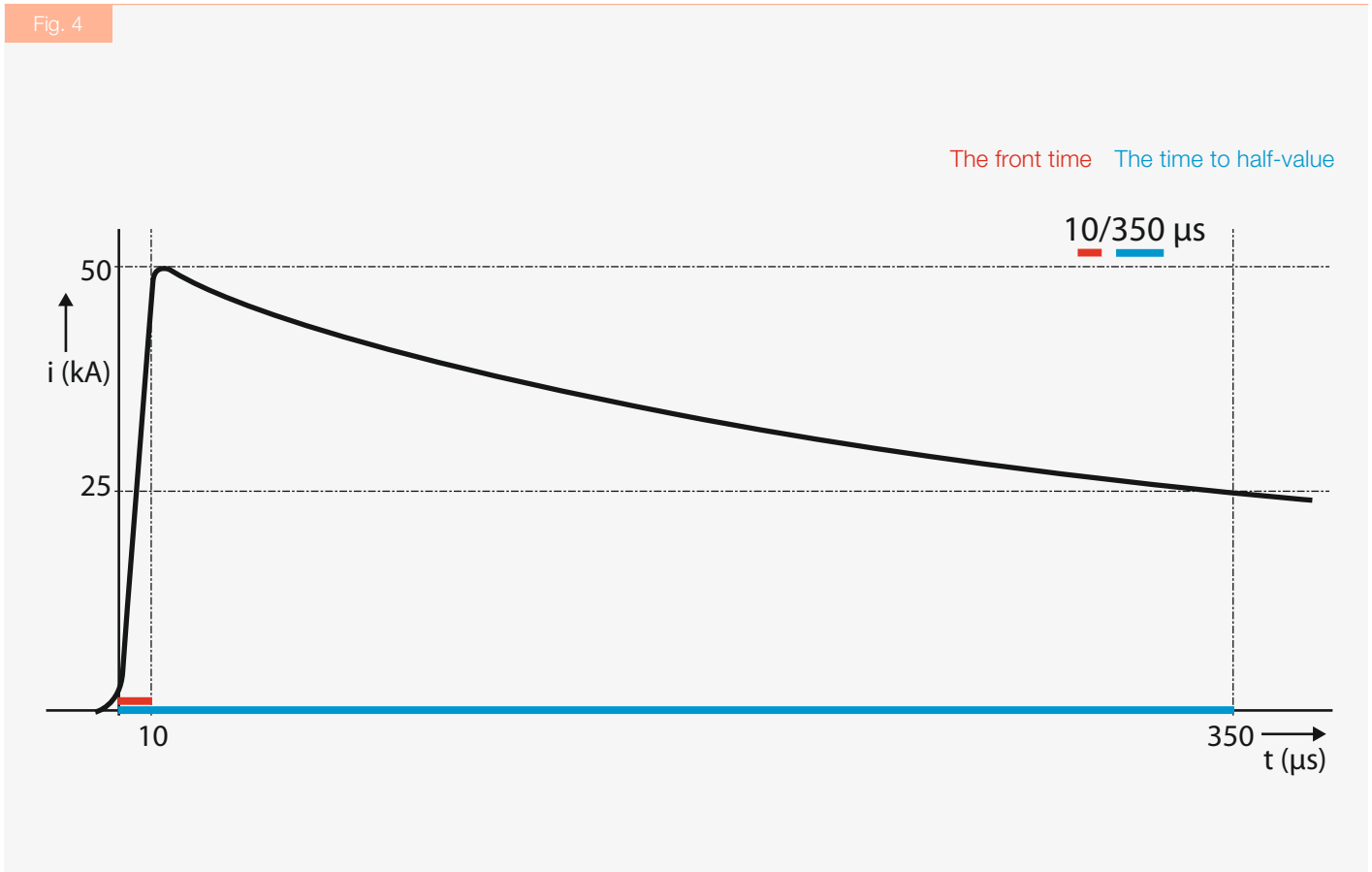

Test impulse 10/350 μs simulates a lightning strike and SPD type 1 and SPD type 1+2 are tested according to it

Fig. 5

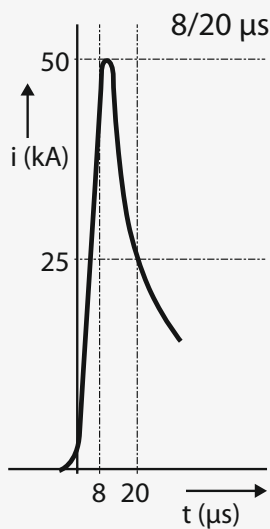

8/20 μ s current impulse simulates surge from switching overvoltage or inductive coupling. This impulse is used for the classification of the SPD for class II test (SPD type 2)

Fig. 6

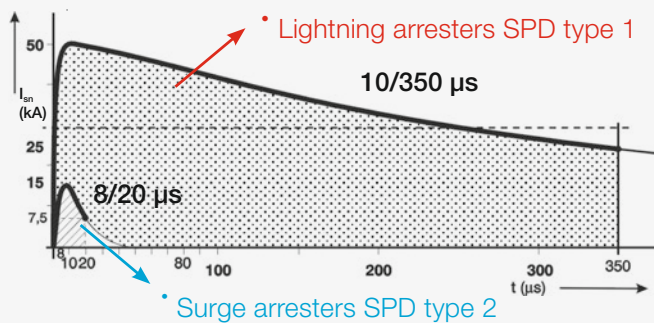

Comparison of the energy of 10/350 μ s and 8/20 μ s testing impulses

Protection of technological equipment against overvoltage

The principle of surge protective devices is based on equipotential bonding. This is conditioned by the effective equalising potential in the whole building. It is only possible if the whole building is thoroughly provided with equipotential bonding and it should be connected to the earthing electrode.

If a building features external lightning protection (LPS), both the down conductor as well as the protective conductor of the supply network should be connected to the earthing conductor. This is shown in the following chapter.

Supply networks – SPD connection principles on how to connect SPDs

An SPD in power supply networks should be connected in two connection modes – mode x+0 (CT1) and mode x+1 (CT2).

The x+0 (CT1) connection mode is designated 3+0 (TN-C) or 4+0 (TN-S) for three-phase power supply and 1+0 (TN-C) or 2+0 (TN-S) for single-phase power supply. Such mode is beneficial in eliminating common mode of overvoltage.

The x+1 (CT2) connection mode is designated 3+1 for three-phase power supply and 1+1 for single-phase power supply. It cannot be used in the TN-C supply network. It is advantageous to use it to eliminate the differential mode of overvoltage.

TN-S system

An SPD type 1 or SPD type 1 and 2 should be located at the incoming supply side to the building (mostly in the main distribution board). These SPDs are mainly intended to restrict lightning electromagnetic impulses (lightning strikes) and therefore are connected in the x+0 pattern, i.e. with all (L1, L2, L3 and N) conductors in live condition against the ground (PE).

An SPD type 2 should be located in a subsidiary distribution board. In such supply networks, the SPD type 2 can either be connected in the x + 0 mode (to eliminate longitudinal – lightning electromagnetic impulse) or in the x + 1 mode (to restrict overvoltage in the equipment).

In a TN-S supply network, connection of a type 2 SPD must follow the type of overvoltage that will prevail in the supply network. Consequently, in industrial operations, where a great number of switching overvoltage occurs, it is more advantageous to connect the SPD type 2 in the x+1 (CT2) mode, while in administrative and residential buildings it is better to connect the SPD type 2 in the x+0 (CT1) mode.

An SPD type 3 is always mounted close to the equipment to be protected.

TN-C-S system

In a TN-C-S supply network, the SPD located before the point from which the PEN conductor separates to the N and PE conductors should always be connected in the x+0 mode. Behind the point of separation, the SPD type 2 can be connected in both the x+1 mode or x+0, with the same principle to be followed as in a TN-S network, i.e., such type of connection should be chosen to better suit the respective situation.

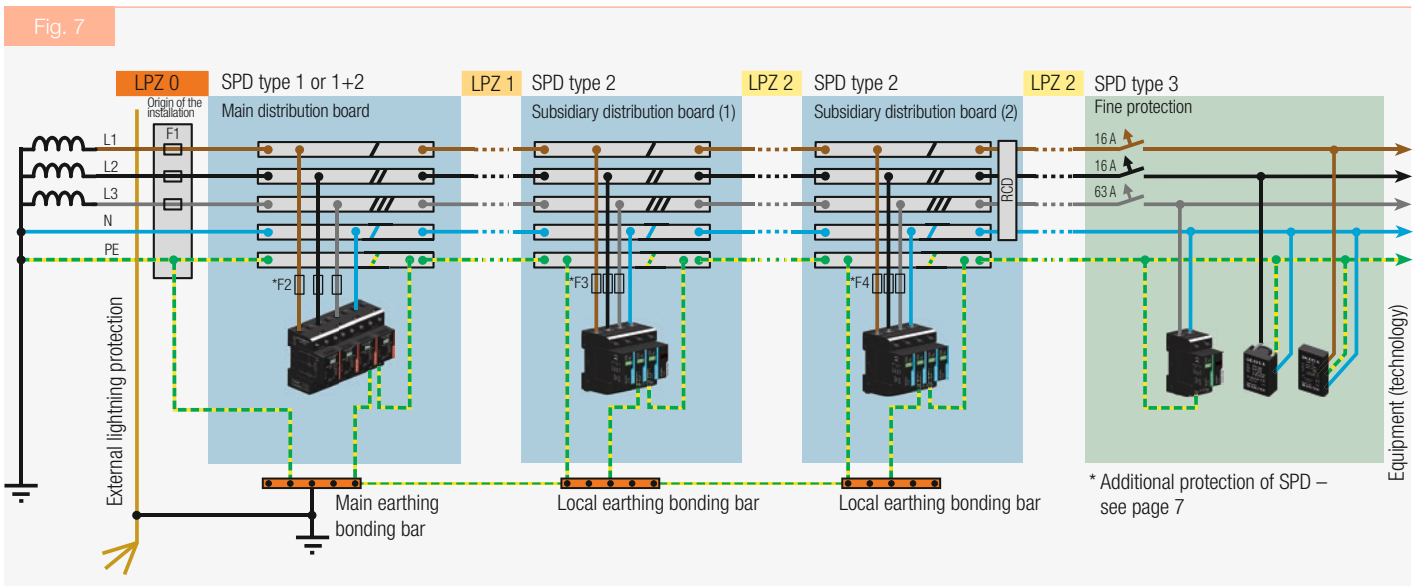

TN-S system

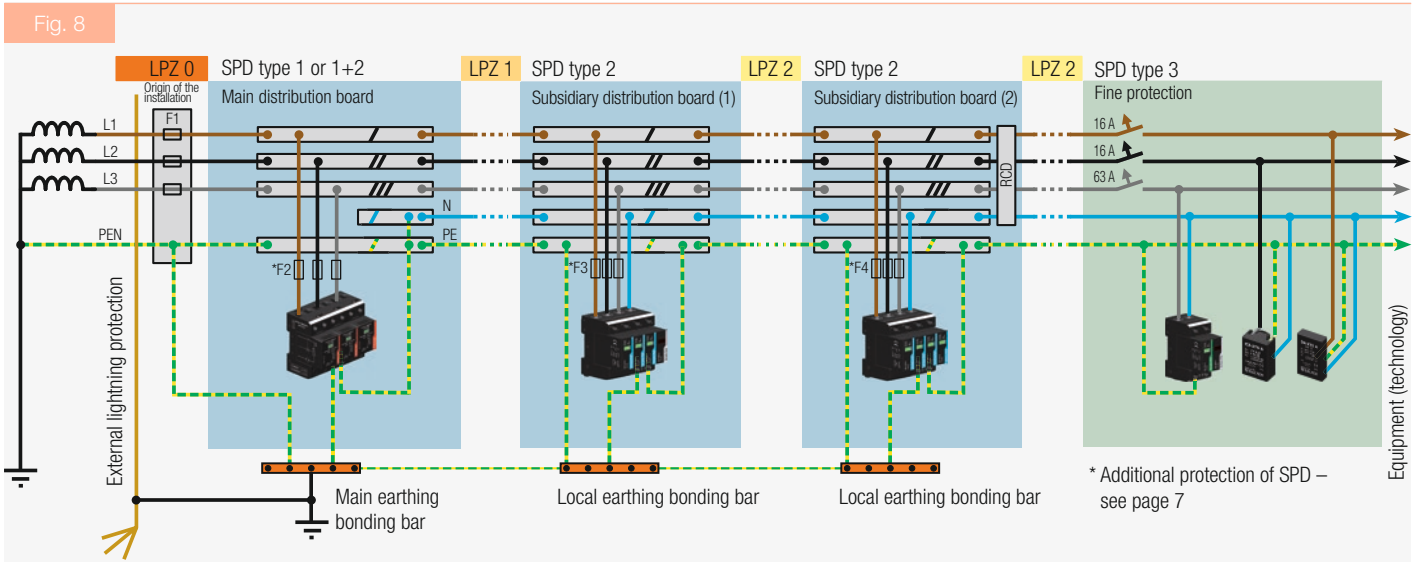

TN-C-S system

TN-C system

In a TN-C supply network, an SPD can only be connected in the x+0 (CT1) mode. Concerning the SPD type 3, wired in the x+1 (CT2) connection mode, the N conductor (blue) as well as the PE conductor (yellow-green) should always be connected to the PEN conductor.

TT system

For a TT supply network, in which only neutral conductors L1, L2, L3 are routed from the power source, all levels of SPD should always be connected in the x+1 (CT2) mode.

Fig. 9

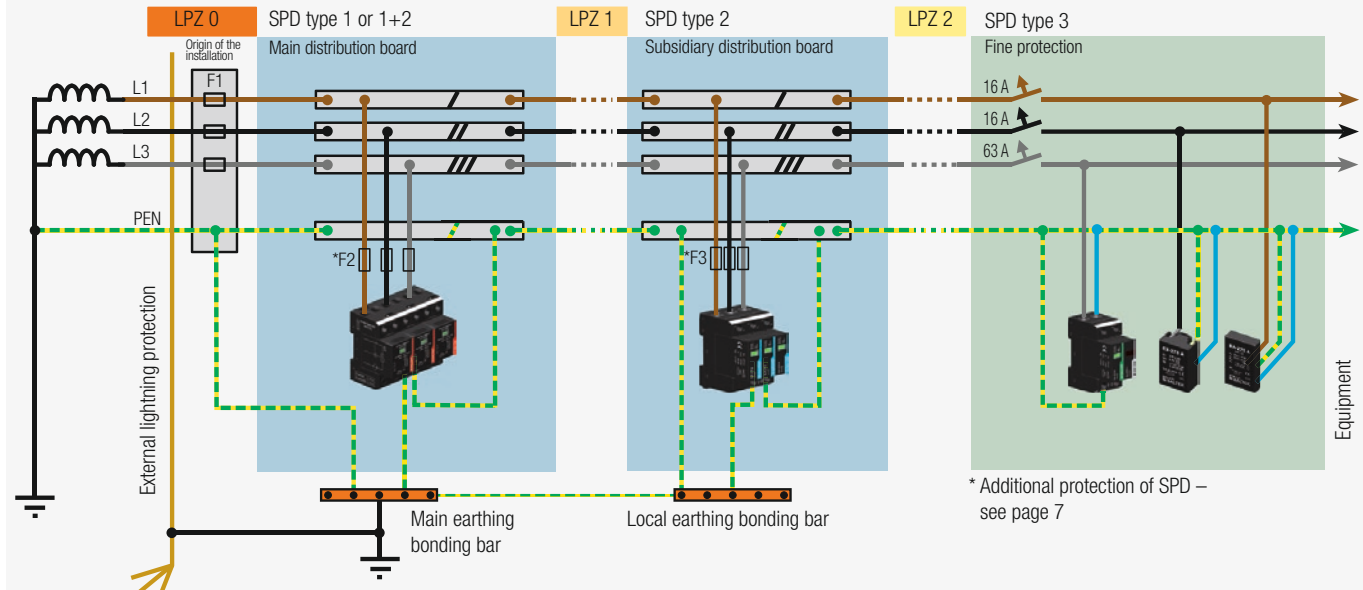

TN-C system

Fig. 10

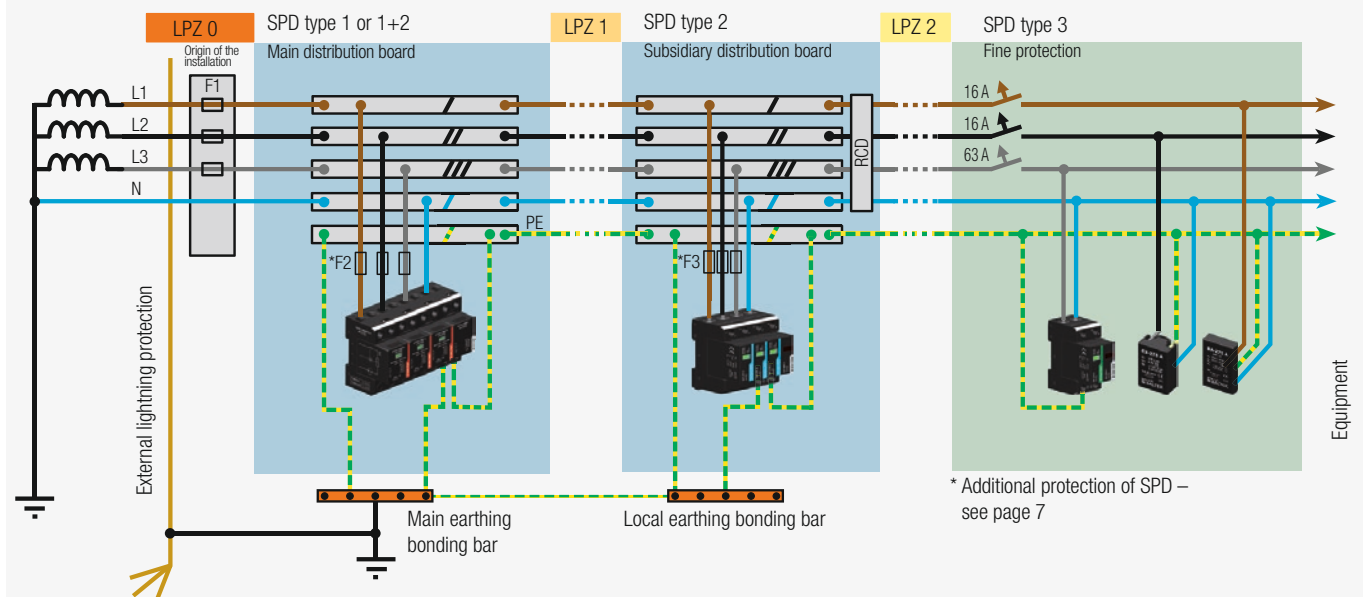

TT system

Principle of overcurrent protection using SPD

For overcurrent protection using SPD it is important to consider whether we should follow the protection priority principle, which is used in most installations, or the power supply priority principle.

In case of the protection priority principle the SPD is pre-protection only if the line protection value (fuse F1) is higher than of SPD in the catalogue (fuse F2), and the SPD protection has always the value specified in the manufacturer's catalogue (column – maximum pre-protection)

An example of back-up fuse for SPD – FLP-B+C MAXI V – in different supply networks.

The catalogue value of maximum back-up fuse for FLP-B+C MAXI V is 250 A, and 125 A for the “V” connection.

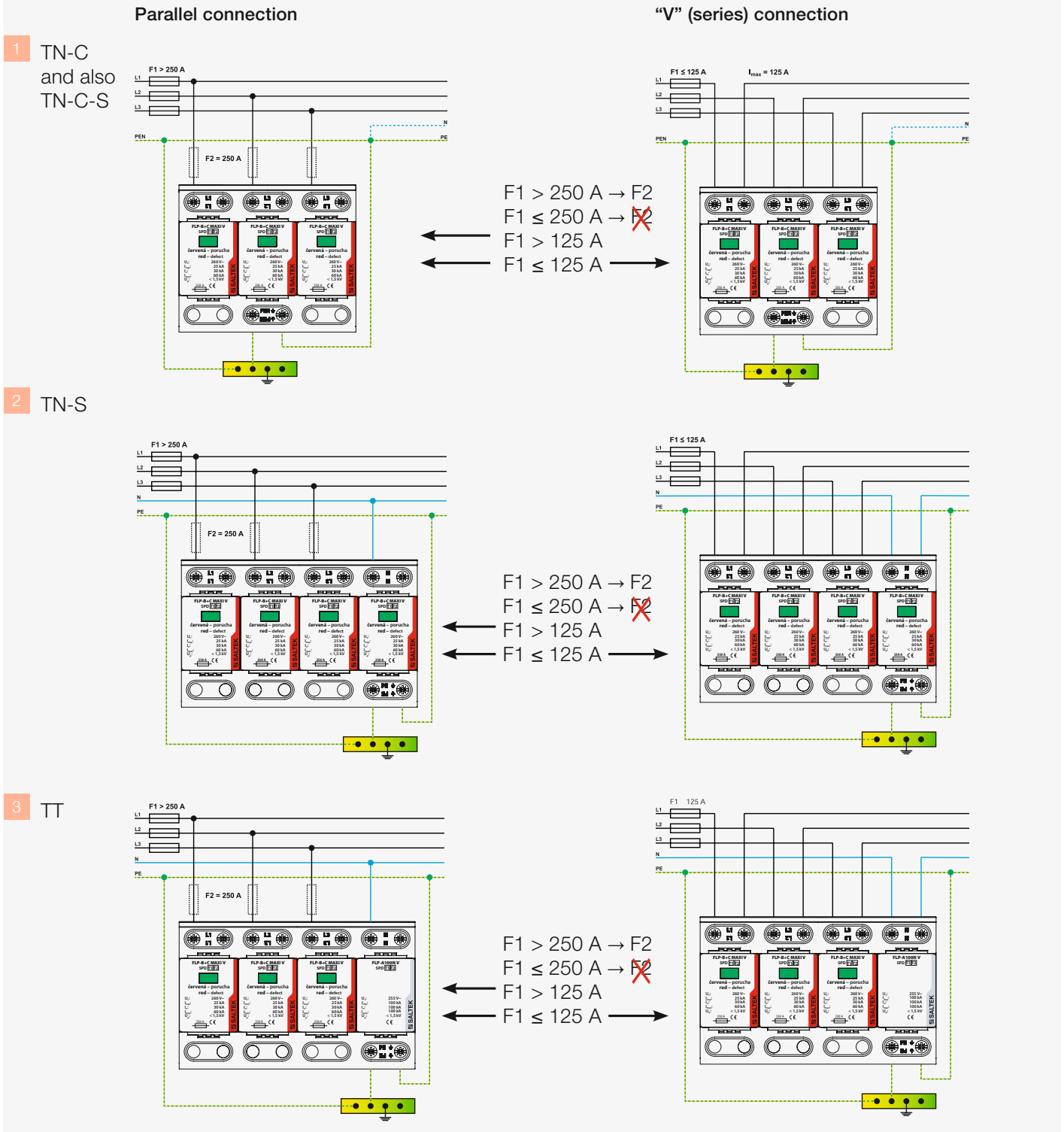

SPD dimensioning

Only the SPD type 1 should be dimensioned. Dimensioning of the SPD type 1 should be based on the calculation of the lightning protection level (LPL) for the lightning protection system (LPS). The table below shows minimum values of

the discharge lightning strike current to the pole considering the lightning protection (LPL) class of the building for the SPD type 1.

If the LPL value is not known, the worse scenario is anticipated			Low voltage networks									
LPL	Maximum current corresponding to LPL	Number of conductors (n)	TT			TN-C	TN-S			IT without neutral conductor		IT with neutral conductor
			Connection mode				Connection mode			Connection mode		
			CT1	CT2			CT1	CT2		CT1	CT2	
			L-PE N-PE	L-N	N-PE	L-PEN	L-PE N-PE	L-N	N-PE	L-PE	L-N	N-PE
1 or unknown	200 kA		I_{imp} (kA)									
		5	N/A	N/A	N/A	N/A	20,0	20,0	80,0	N/A	N/A	N/A
		4	25,0	25,0	100,0	25,0	N/A	N/A	N/A	N/A	25,0	100,0
		3	N/A	N/A	N/A	N/A	33,3	33,3	66,7	33,3	N/A	N/A
		2	50,0	50,0	100,0	50,0	N/A	N/A	N/A	N/A	50,0	100,0
2	150 kA		I_{imp} (kA)									
		5	N/A	N/A	N/A	N/A	15,0	15,0	60,0	N/A	N/A	N/A
		4	18,8	18,8	75,0	18,8	N/A	N/A	N/A	N/A	18,8	75,0
		3	N/A	N/A	N/A	N/A	25,0	25,0	50,0	25,0	N/A	N/A
		2	37,5	37,5	75,0	37,5	N/A	N/A	N/A	N/A	37,5	75,0
3 or 4	100 kA		I_{imp} (kA)									
		5	N/A	N/A	N/A	N/A	10,0	10,0	40,0	N/A	N/A	N/A
		4	12,5	12,5	50,0	12,5	N/A	N/A	N/A	N/A	12,5	50,0
		3	N/A	N/A	N/A	N/A	16,7	16,7	33,3	16,7	N/A	N/A
		2	25,0	25,0	50,0	25,0	N/A	N/A	N/A	N/A	25,0	50,0

Table 1

Note: CT1 – SPD connected in the x+0 mode; CT2 – SPD connected in the x+1 mode

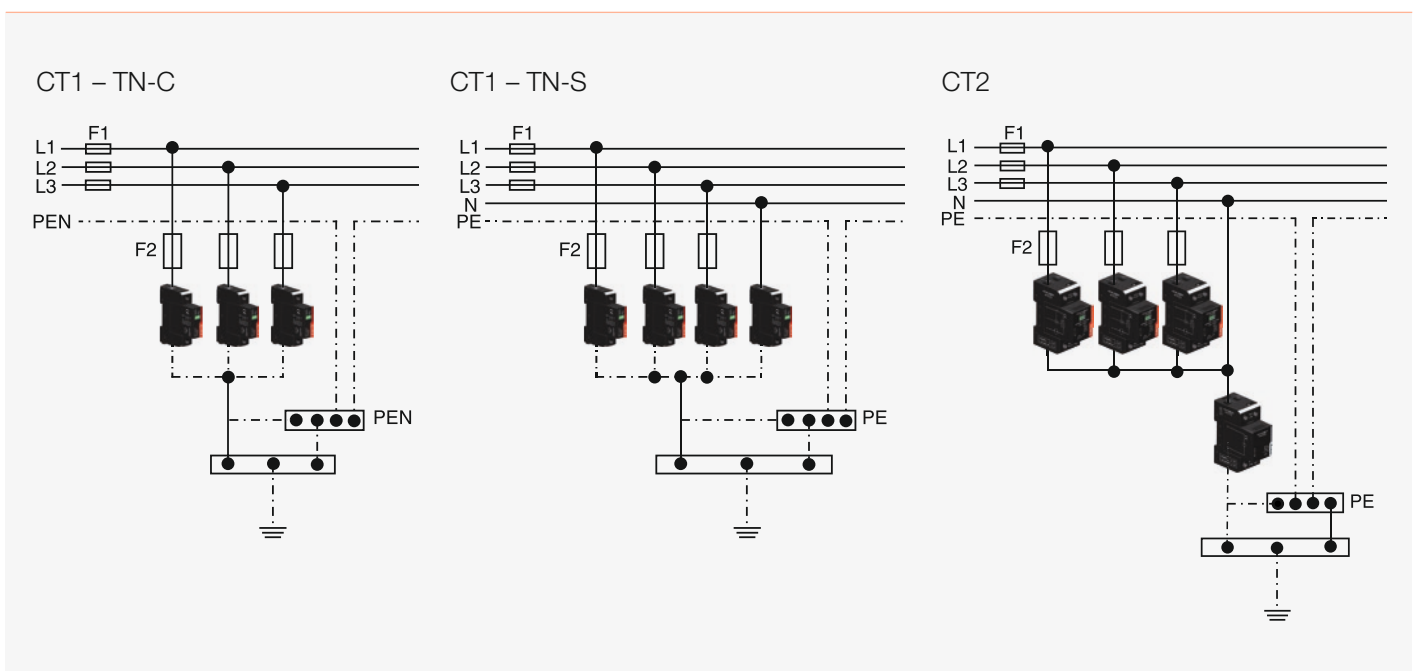

Selection of SPD at the incoming supply side to the building

For selection of the SPD type 1 at the incoming supply to the building we use the table for SPD type 1 dimensioning (see table 1). At the same time, it is necessary to consider the specific situation. Even if the calculation made according to the previous table shows that the Impulse current of SPD

type 1 may be, for example, 12.5 kA in a 10/350 μ s wave and the building is fed by external cabling, then the probability of a lightning strike into the outdoor line is high and the SPD type 1 would be under-dimensioned.

Variants of SPD applications are shown in the following examples:

Situation at the entrance of structure	Solution
A house with LPS, earthed antenna, or metallic roof, etc.	SPD type 1 <input checked="" type="checkbox"/> SPD type 2 <input checked="" type="checkbox"/>
A house with an overhead line	SPD type 1 <input checked="" type="checkbox"/> SPD type 2 <input checked="" type="checkbox"/>
A house with earthed metallic parts or LPS nearby	SPD type 1 <input checked="" type="checkbox"/> SPD type 2 <input checked="" type="checkbox"/>

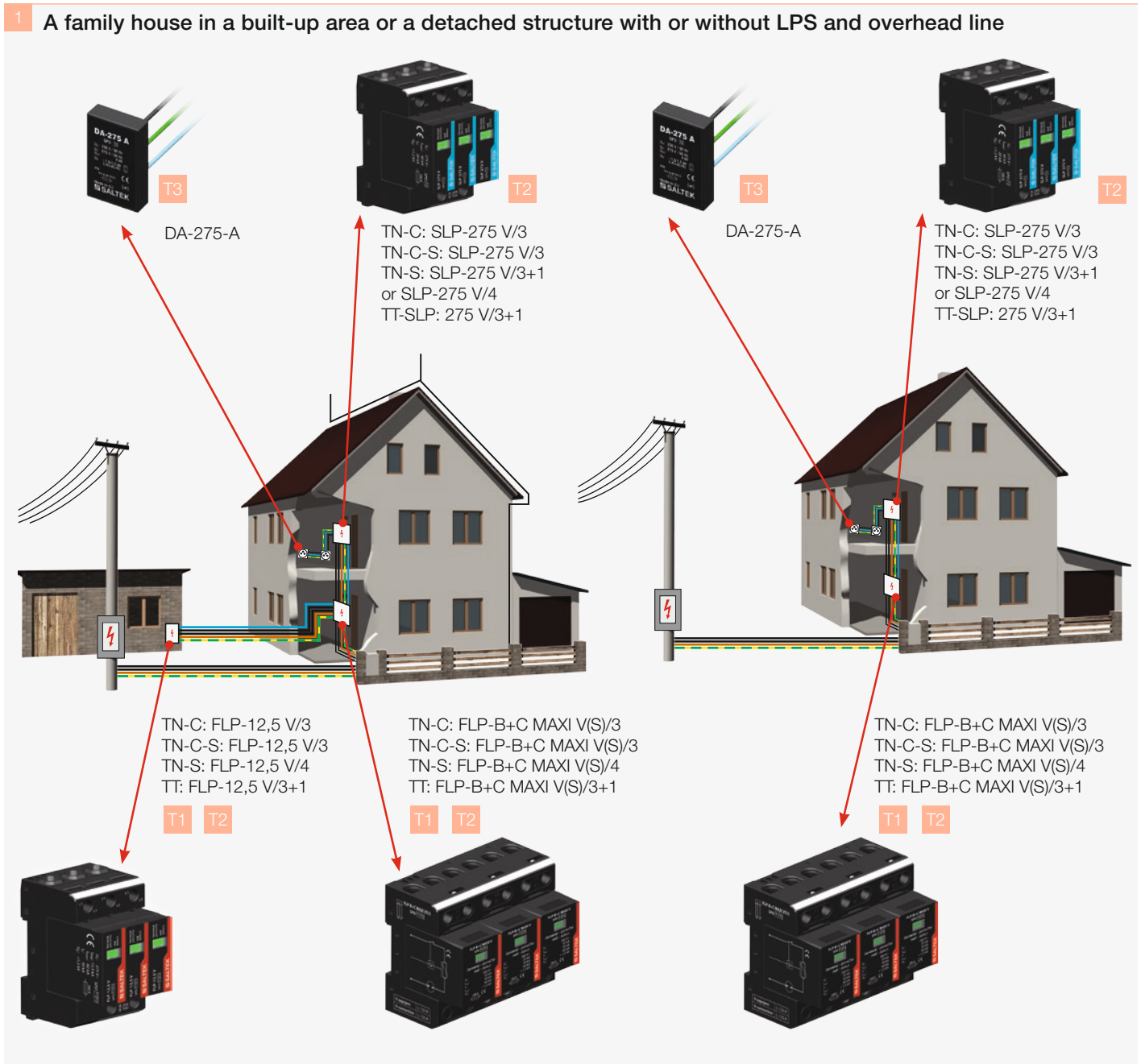

2 A detached family house with or without LPS, with an underground cable connection

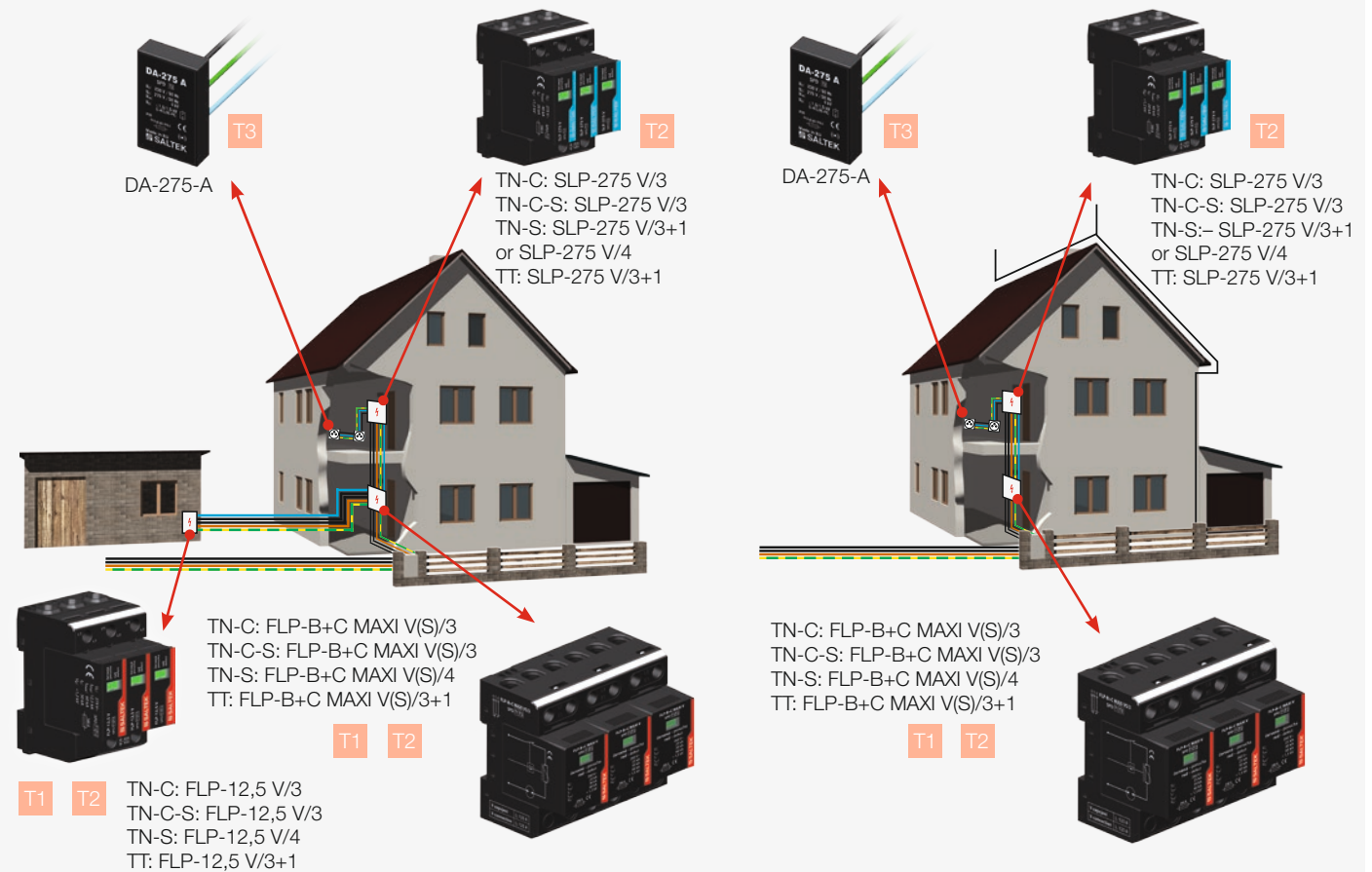

3 A family house in a built-up area without LPS and with an underground cable connection

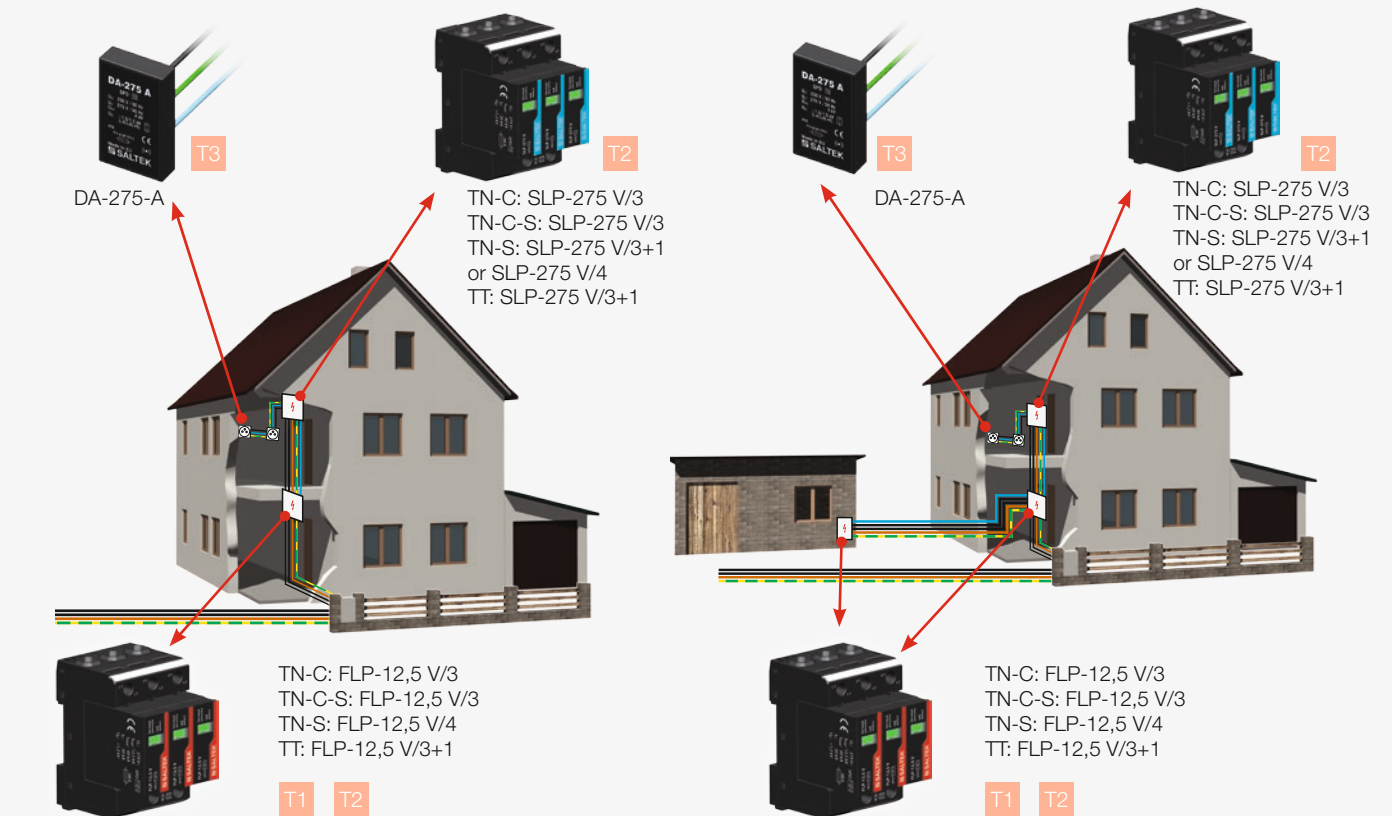

4 Terrace houses with a common LPS and overhead line

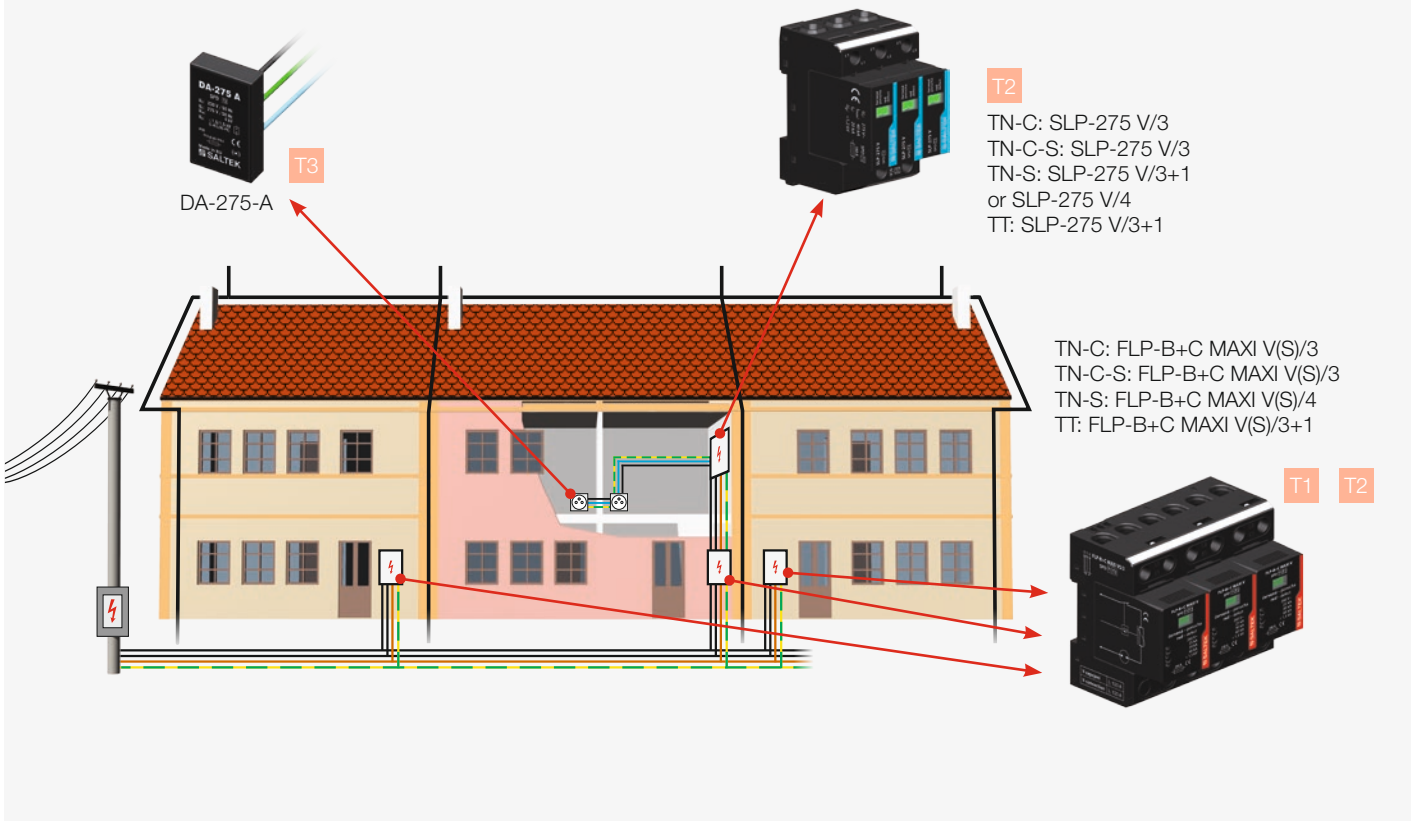

5 Terrace houses with a common LPS and an underground cable connection

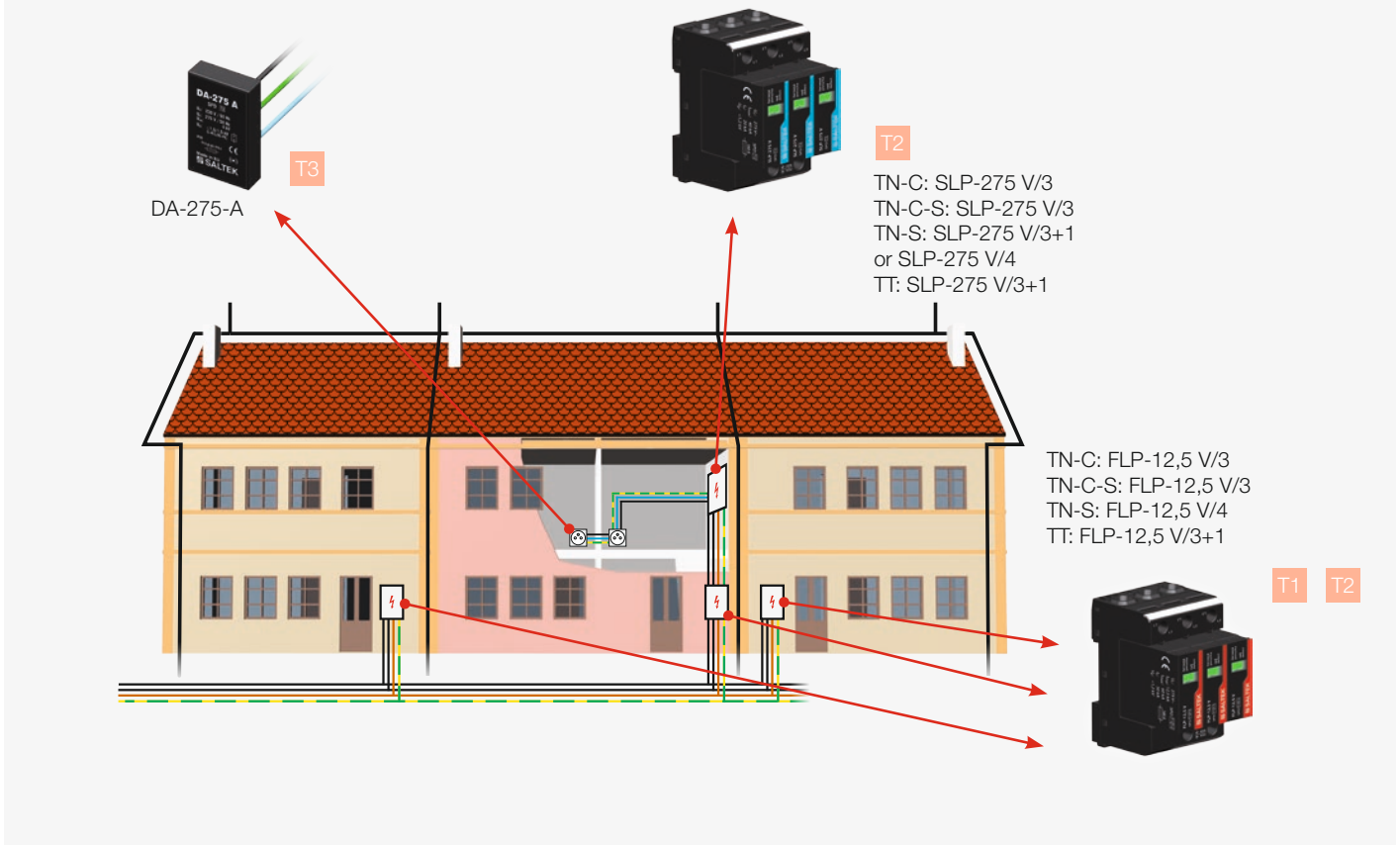

6 Blocks of flats with an underground cable connection without the possibility to install an SPD type 1 upstream of power meter

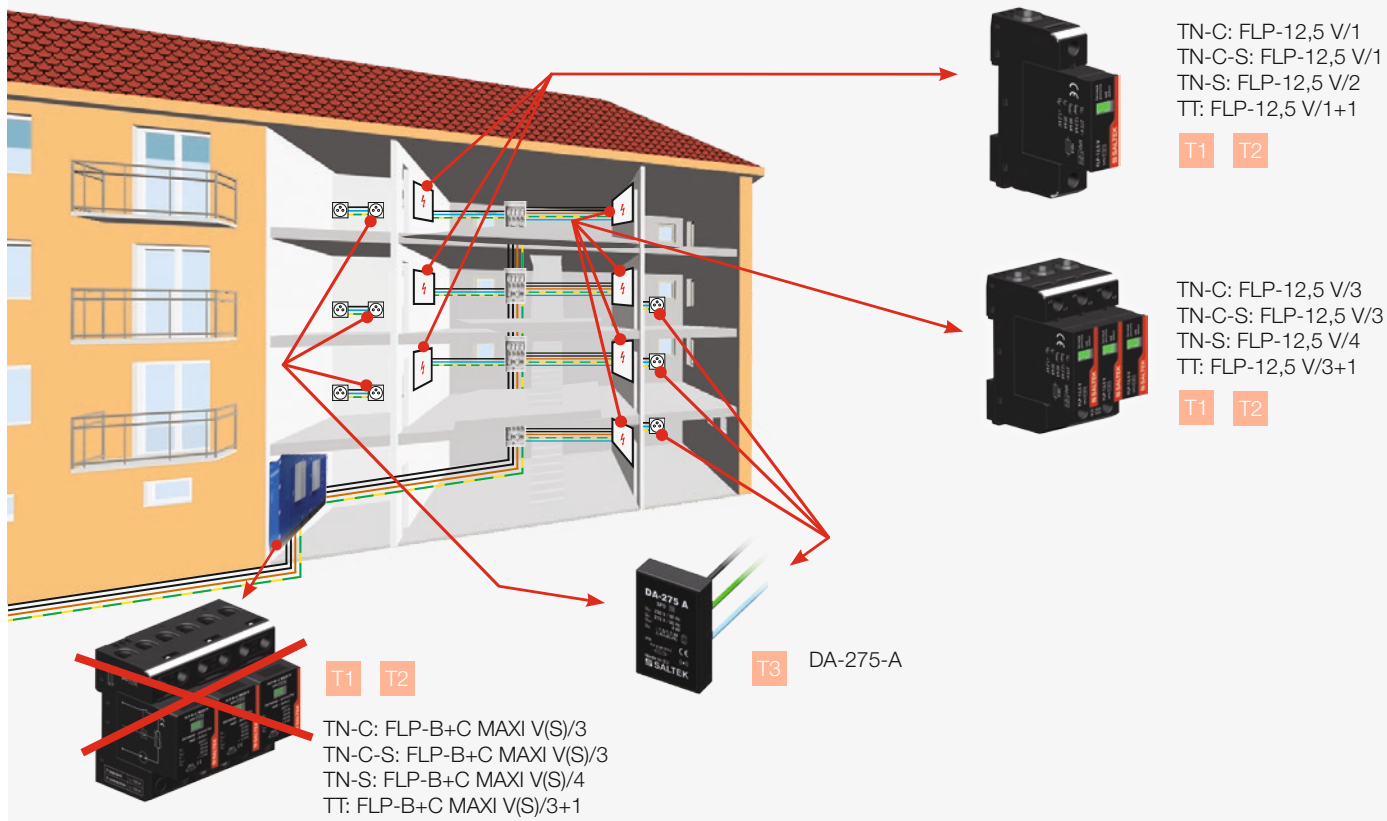

7 Blocks of flats with an underground cable connection with the possibility to install an SPD type 1 upstream of power meter

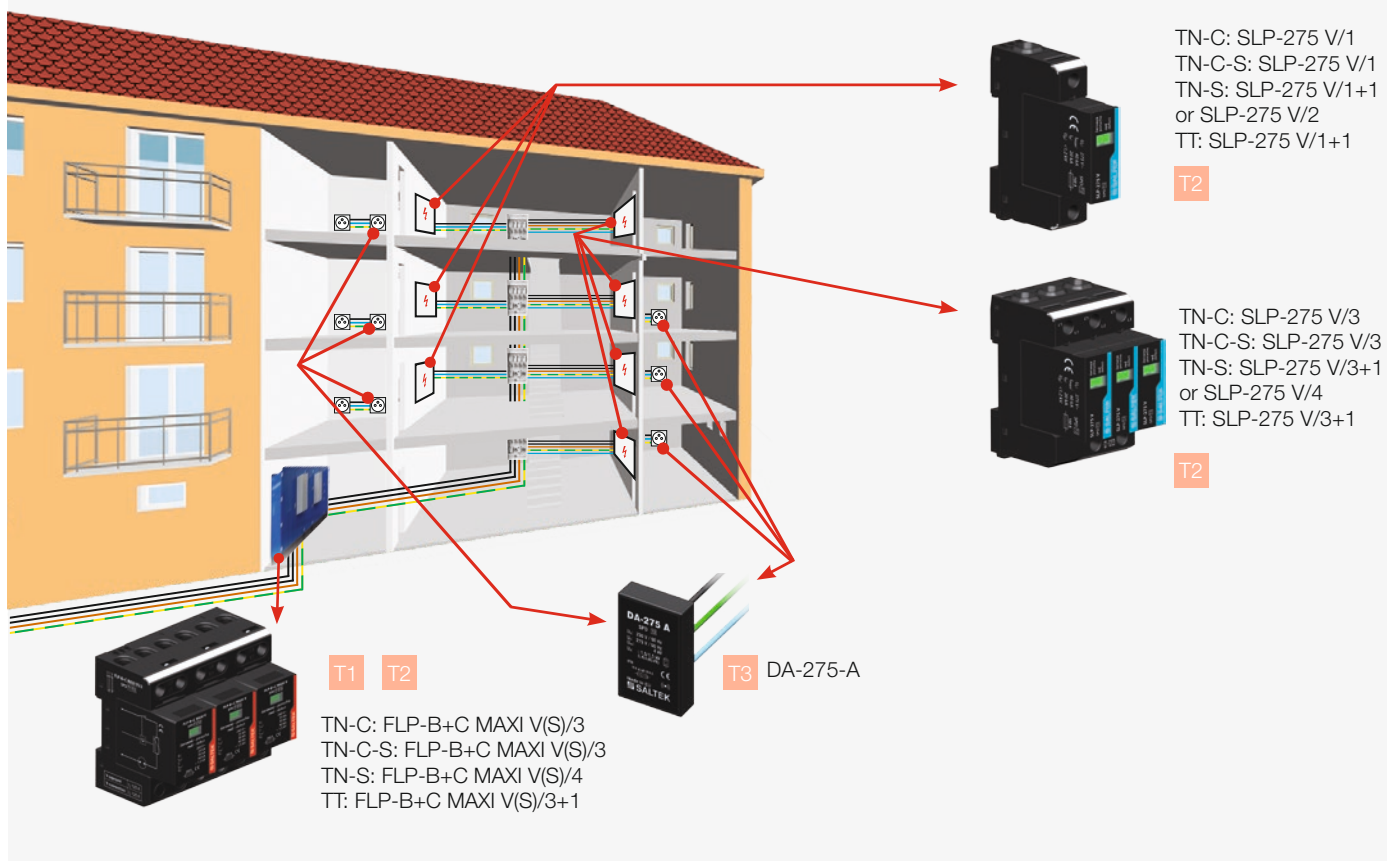

8 Administration building

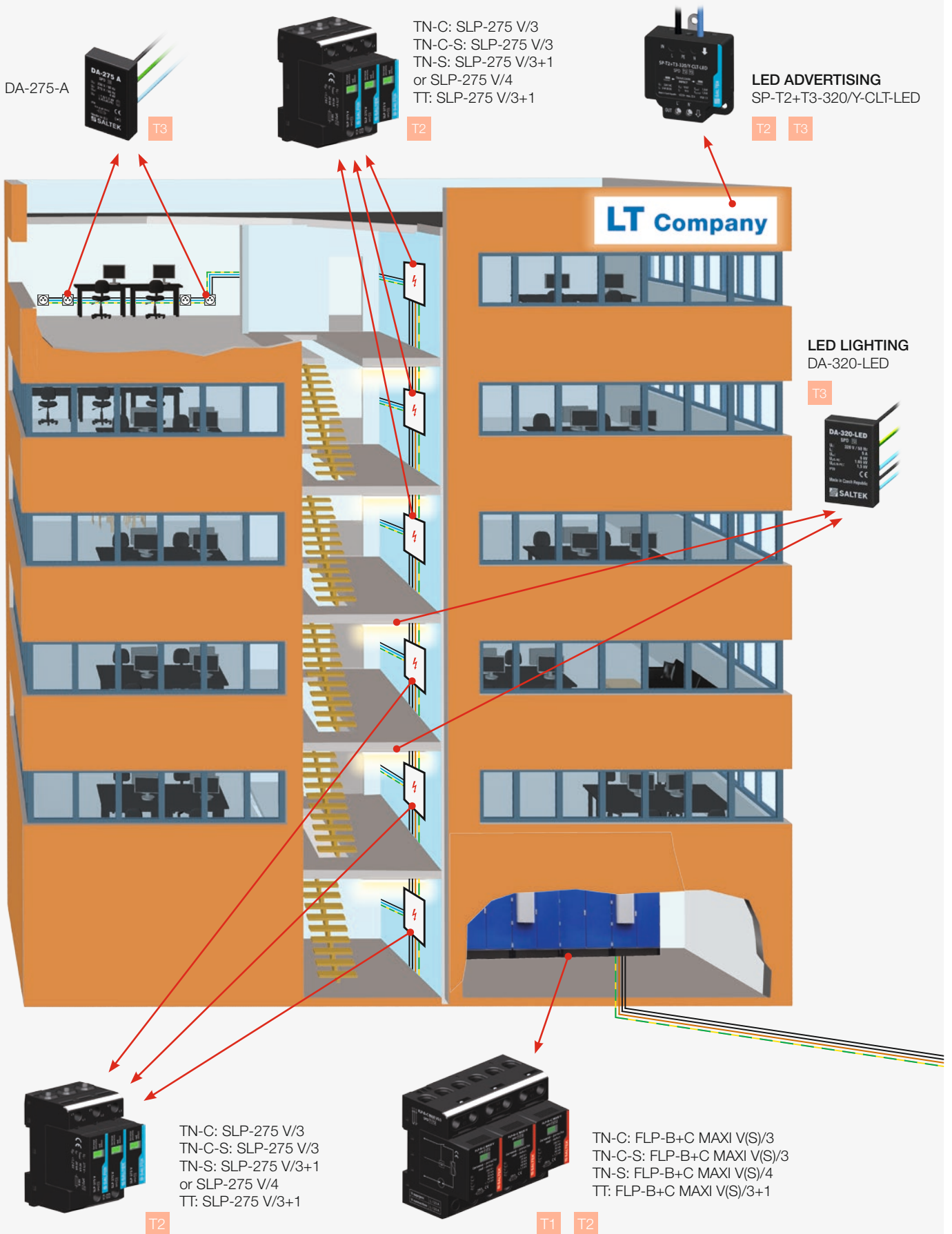

9 Administrative and commercial premises

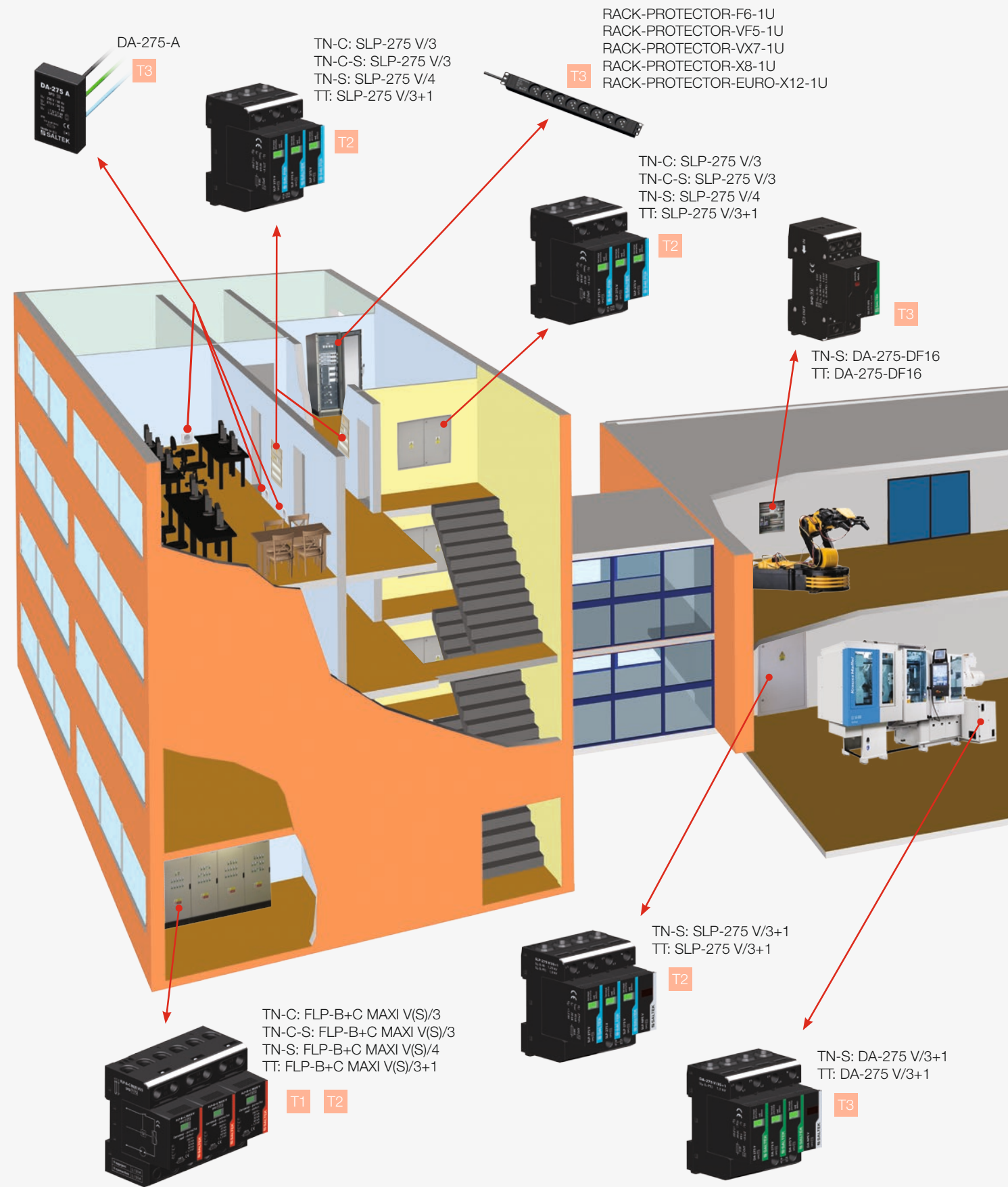

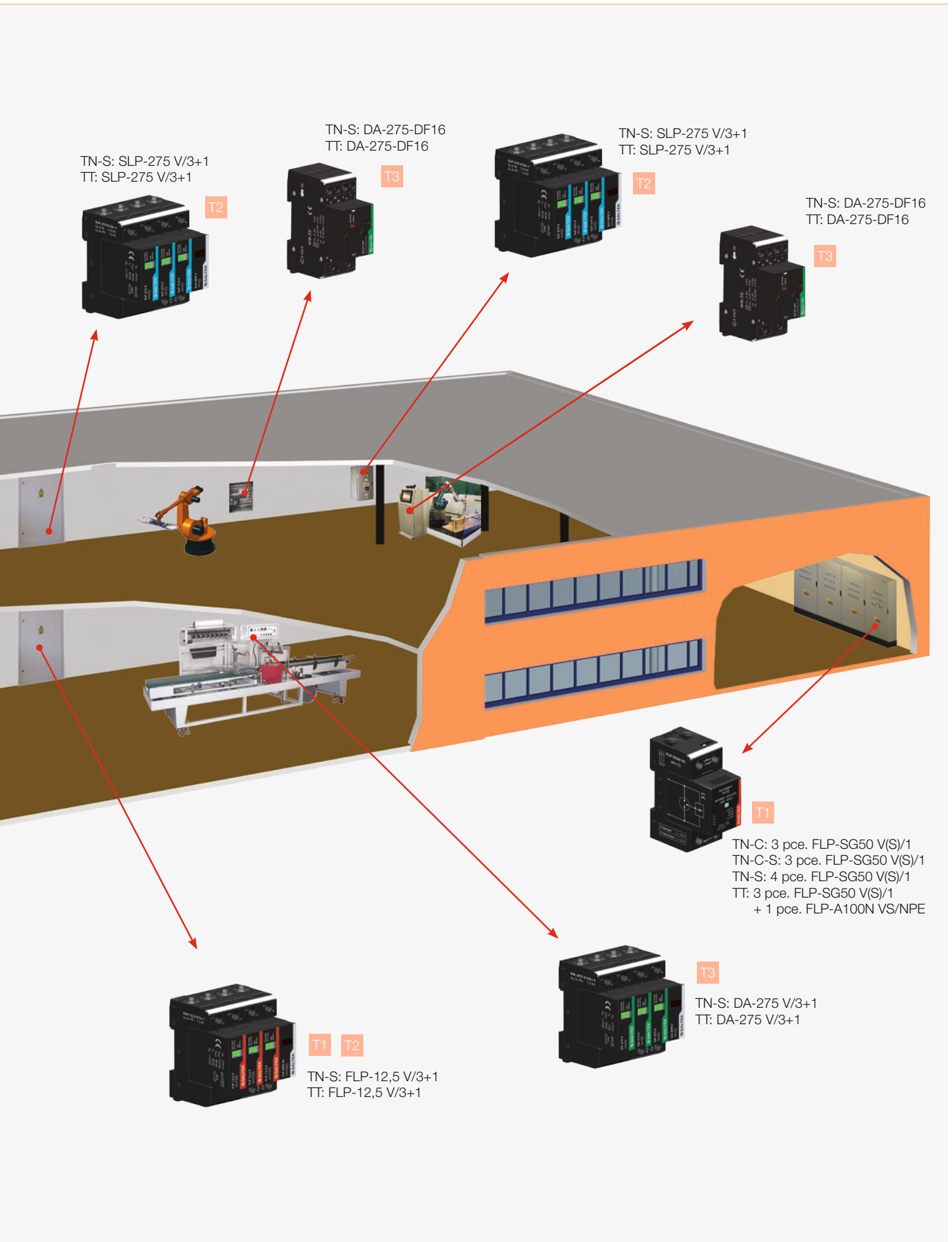

10 Commercial building

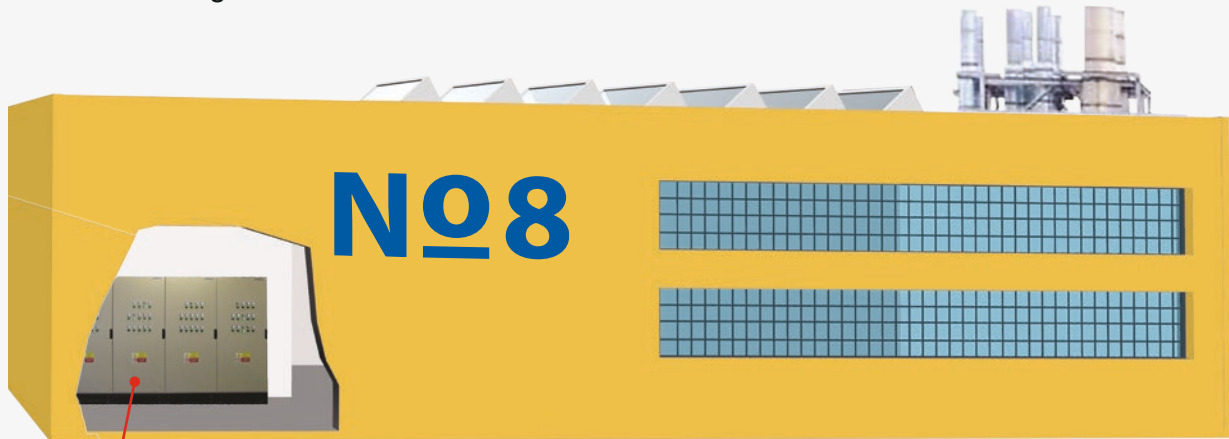

T1 T2

TN-C: FLP-B+C MAXI V(S)/3
 TN-C-S: FLP-B+C MAXI V(S)/3
 TN-S: FLP-B+C MAXI V(S)/4
 TT: FLP-B+C MAXI V(S)/3+1

or



T1

or



T1

and



T2

TN-C: FLP-25-T1-V(S)/3
 TN-C-S: FLP-25-T1-V(S)/3
 TN-S: FLP-25-T1-V(S)/4
 TT: FLP-25-T1-V(S)/3+1

TN-C: 3 pce. FLP-SG50 V(S)/1
 TN-C-S: 3 pce. FLP-SG50 V(S)/1
 TN-S: 4 pce. FLP-SG50 V(S)/1
 TT: 3 pce. FLP-SG50 V(S)/1
 + 1 pce. FLP-A100N VS/NPE

TN-C: SLP-275 V/3
 TN-C-S: SLP-275 V/3
 TN-S: SLP-275 V/4
 TT: SLP-275 V/3+1

11 Commercial building of special importance

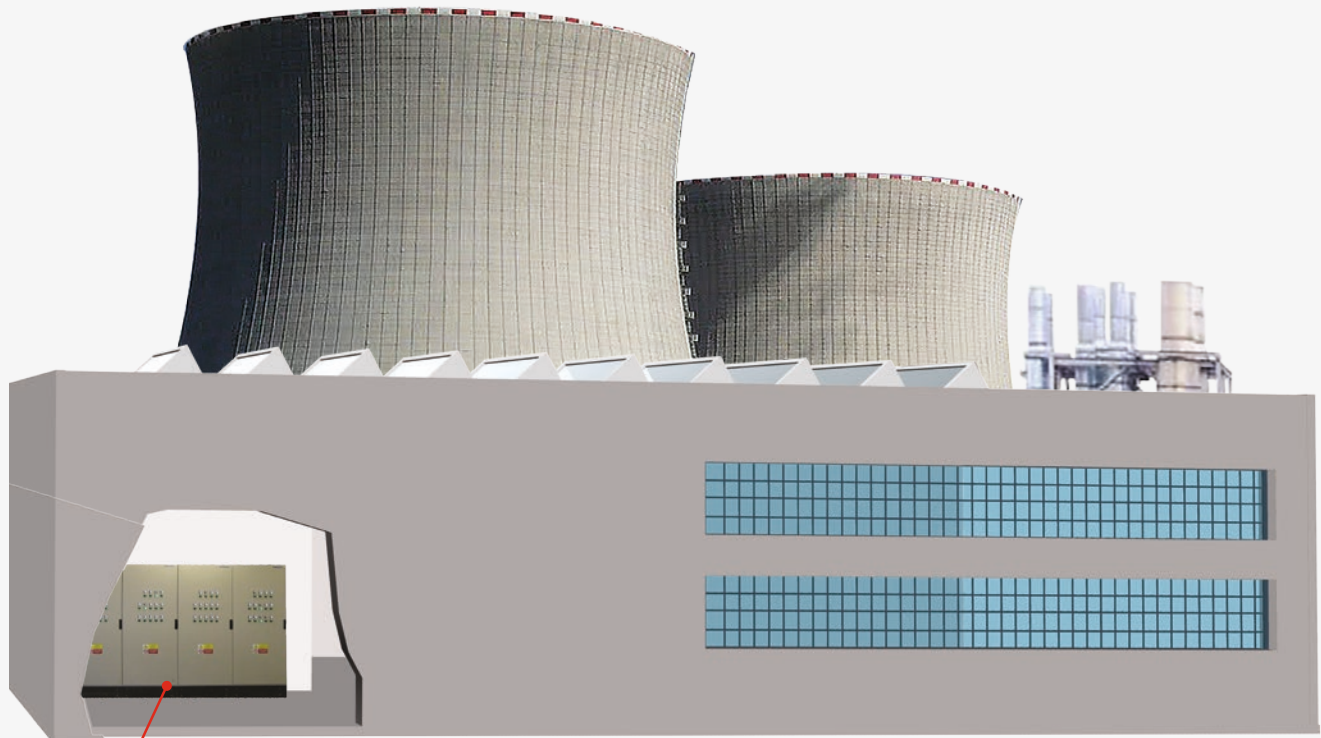

T1

TN-C: 3 pce. FLP-SG50 V(S)/1
 TN-C-S: 3 pce. FLP-SG50 V(S)/1
 TN-S: 4 pce. FLP-SG50 V(S)/1
 TT: 3 pce. FLP-SG50 V(S)/1 + 1 pce. FLP-A100N VS/NPE

12 Building with LPS and air conditioner or heating cables in gutters

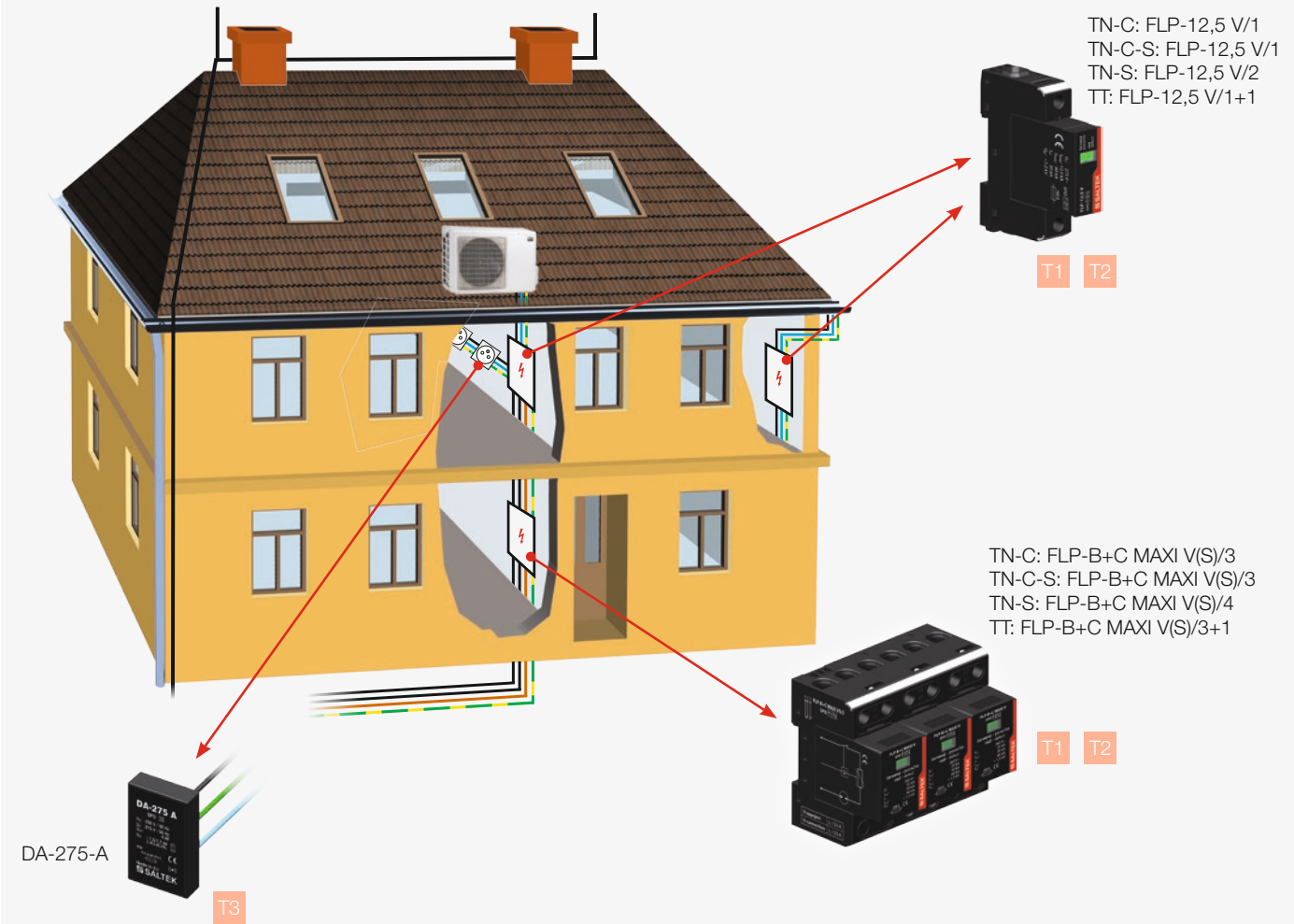

13 House with a single-phase power supply and LPS (LPL I)

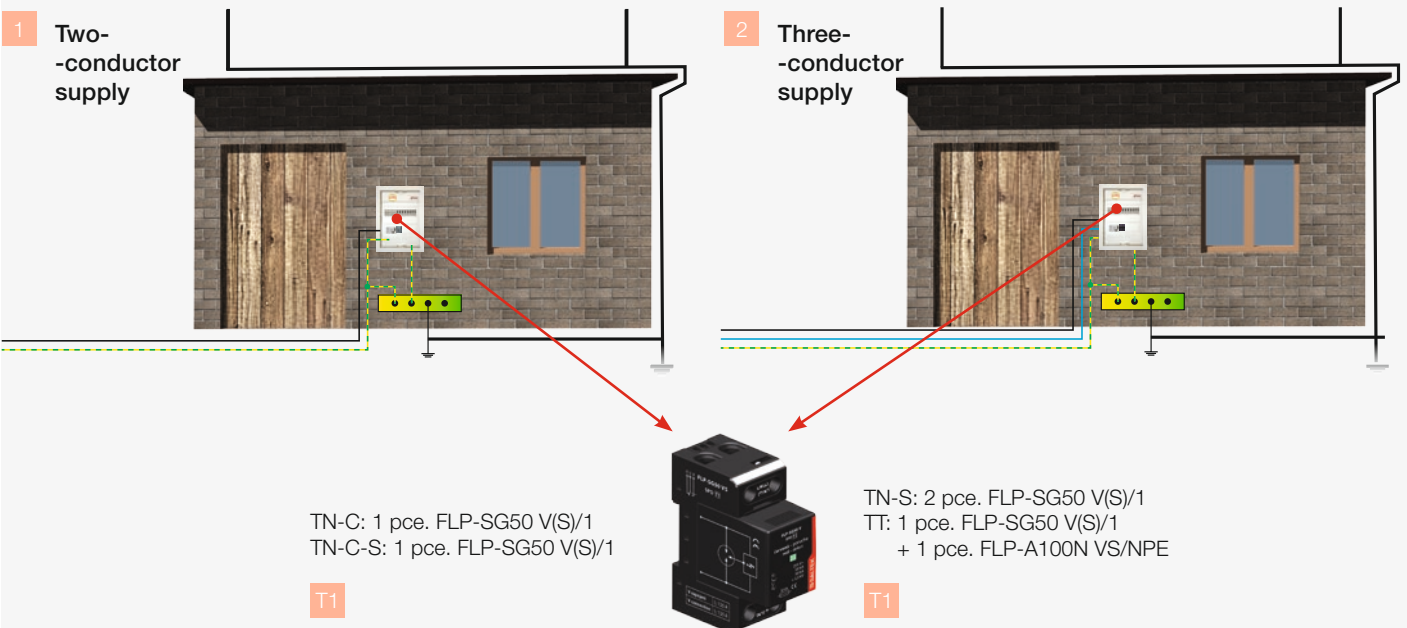

Reduction of overvoltage in LPZ zones

The principle of voltage reduction using zones lies in progressive reduction of the overvoltage level to a safe value that will not damage the specific equipment or technology.

To obtain a safe overvoltage value, the whole structure is divided into individual zones and the SPD is installed at the boundary between the zones.

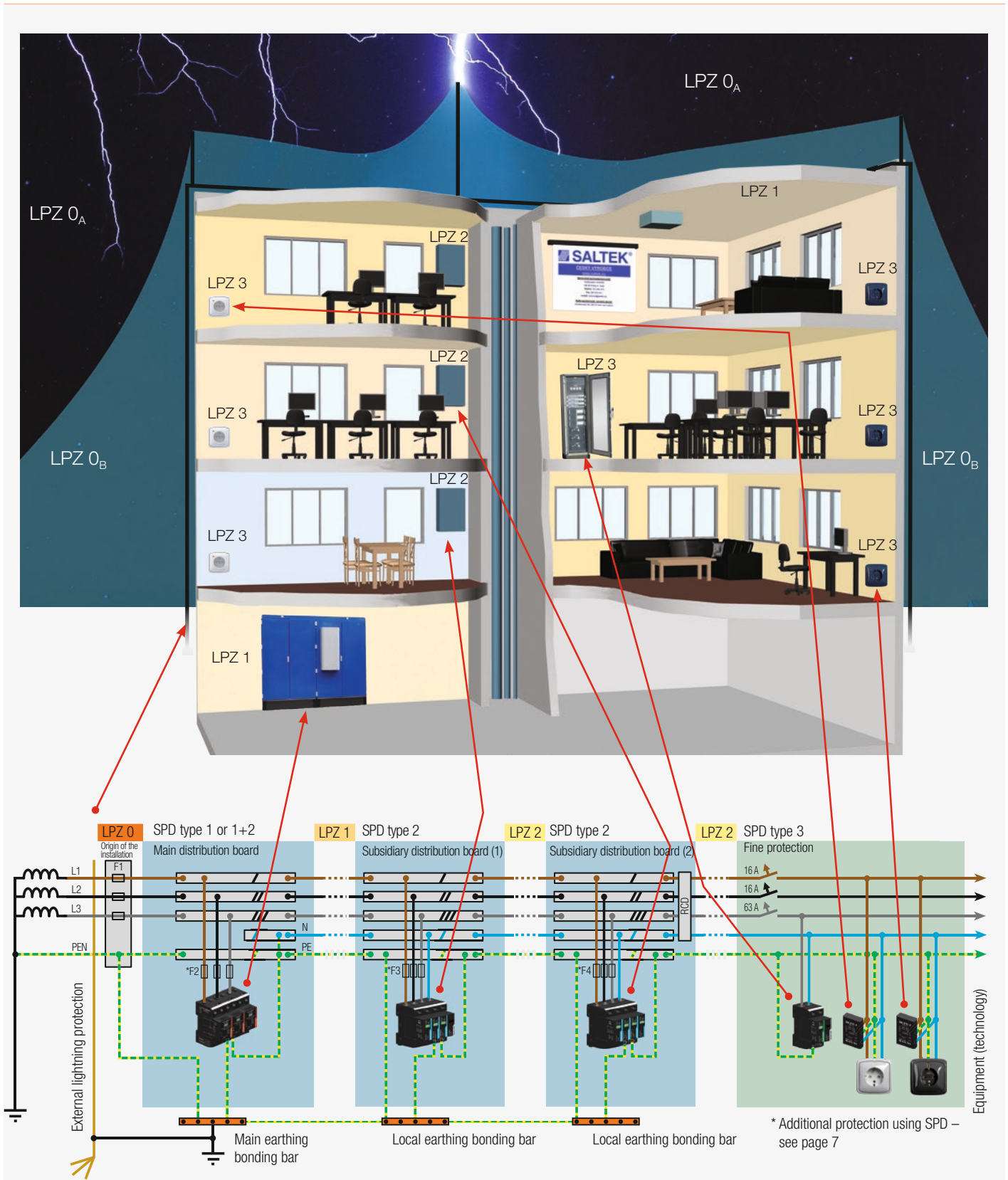

SPD mounting – principles

Principle 1 – length of connecting conductors

If you want to protect equipment, there are several things to remember when installing an SPD, i.e., apart from its diverting ability, it is the maximum value of voltage protective level to be withheld by the equipment at its terminals considering the installation method. Protection level U_p and the drop in voltage at the supply conductors ΔU must not exceed the withstand voltage at the terminals of the equipment.

Fig. 11 clearly shows that the aggregate protection level is given by adding partial reductions in voltage, while such a sum must not exceed 80% of the withstand voltage U_w at the terminals of the equipment.

$$U_w > U_p + \Delta U_1 + \Delta U_2$$

where U_w ... withstand voltage
 U_p ... voltage protection level
 $\Delta U_1, \Delta U_2$... reduction in voltage at the supply conductor.

The impedance of supply conductors for high frequency currents is approximately $1 \mu\text{H}$ per 1 m of conductor length.

The voltage drop in this conductor is given by the formula:

$$\Delta U = L \times di/dt$$

So with a steepness of the pulse rise time of $1 \text{ kA}/\mu\text{s}$, there is a reduction of 1,000 V per 1 m of length, which is added to the protection voltage level of the SPD itself. With the total length of supply conductors being 0.5 m, 500 V will be added to the protection voltage level U . Consequently, the length of the supply conductors must be as short as possible and should not exceed an aggregate length of 0.5 m, as shown in the following figures (Fig. 12 and Fig. 13), depicting the connection options.

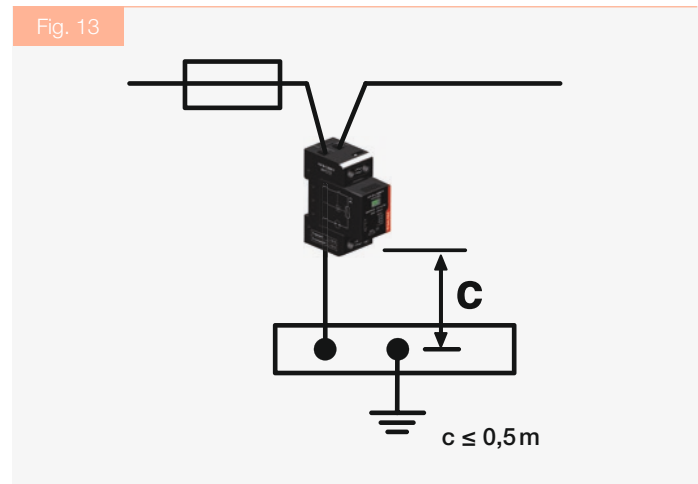
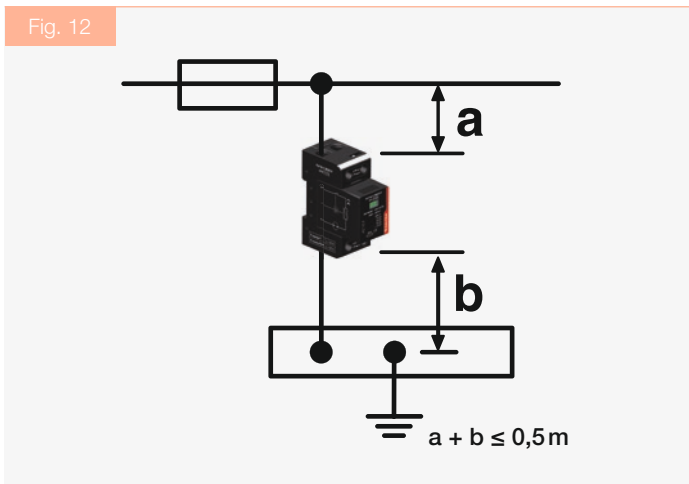
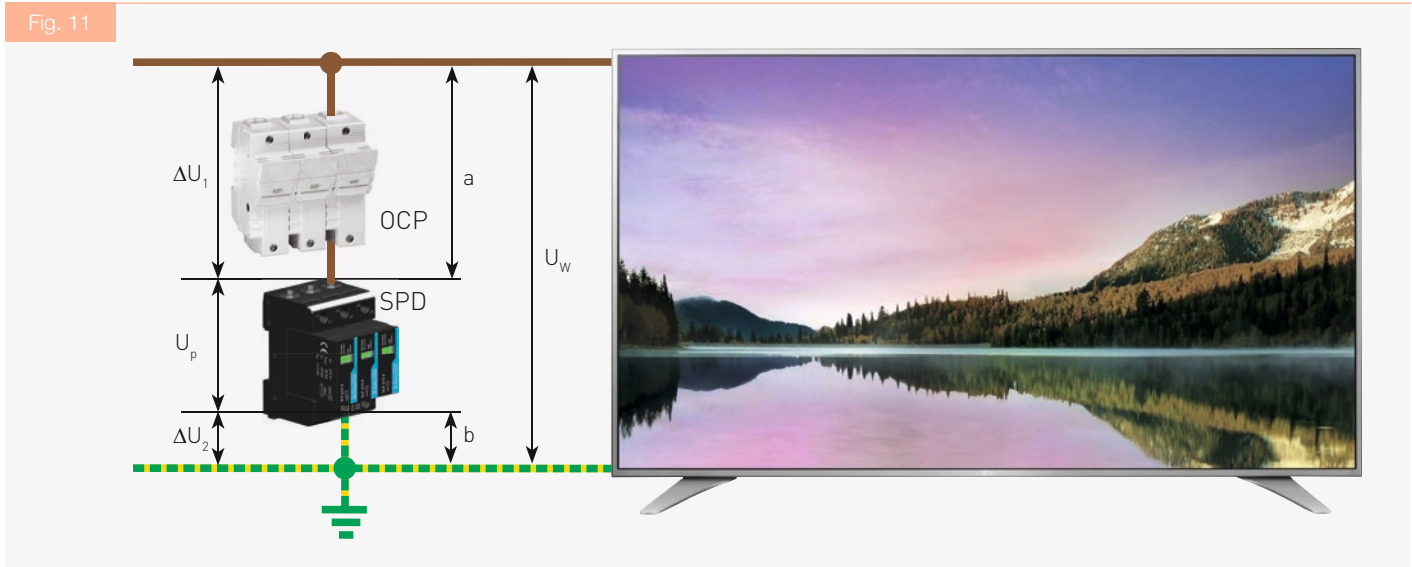

The two pictures below illustrate how the stipulated conductor length of ≤ 0.5 m to connect the SPD can be met in practice.

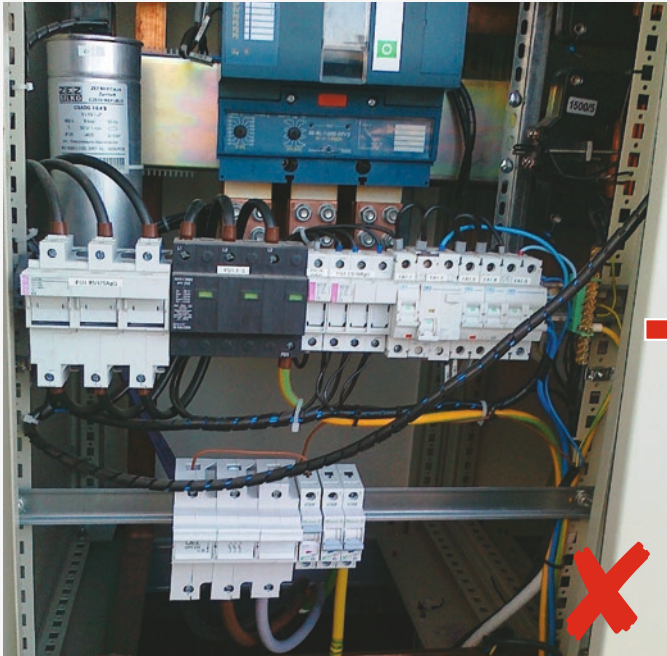

Before the intervention: The SPD installation fails to meet the condition as regards the length of supply conductors for the SPD

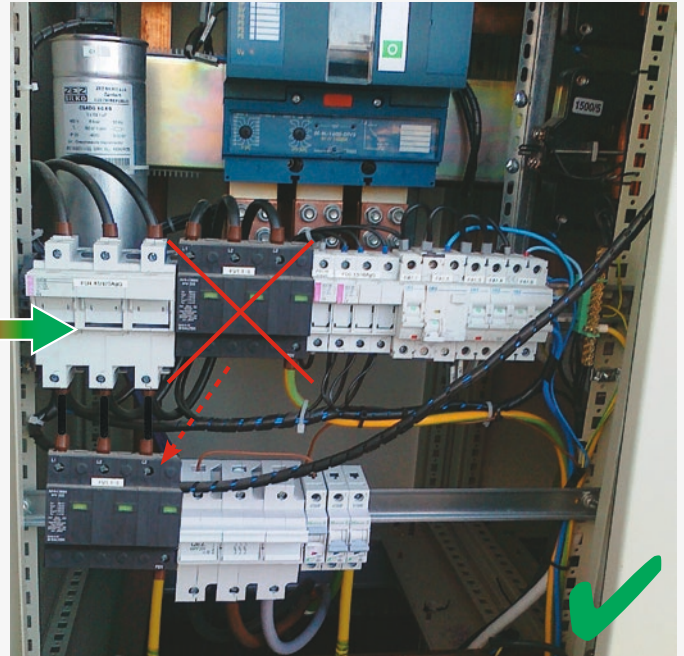

After the intervention: By relocating the SPD the condition above will be satisfied.



Before the intervention: The SPD installation fails to meet the condition as regards the length of supply conductors

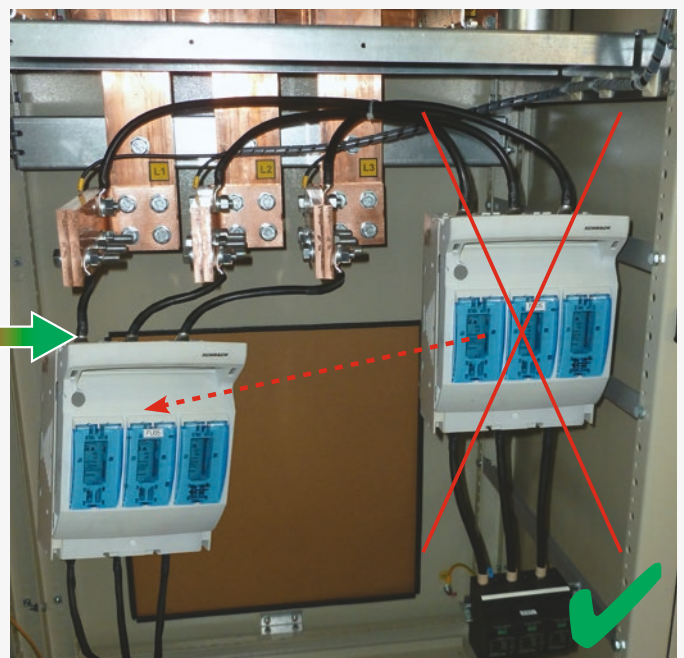

After the intervention: By relocating the SPD the condition will be satisfied

Principle 2 – Locating the SPD in the distribution board

An SPD in the distribution board is located at the entry of the customer’s structure, to eliminate as early as possible any surges entering the supply line, and to prevent their effects on appliances installed in the distribution board. It makes

sure the unprotected conductors (affected by overvoltage) are kept as short as possible and the overvoltage that could be induced in conductors protected by the SPD is minimized. Basic options are shown in Fig. 14.

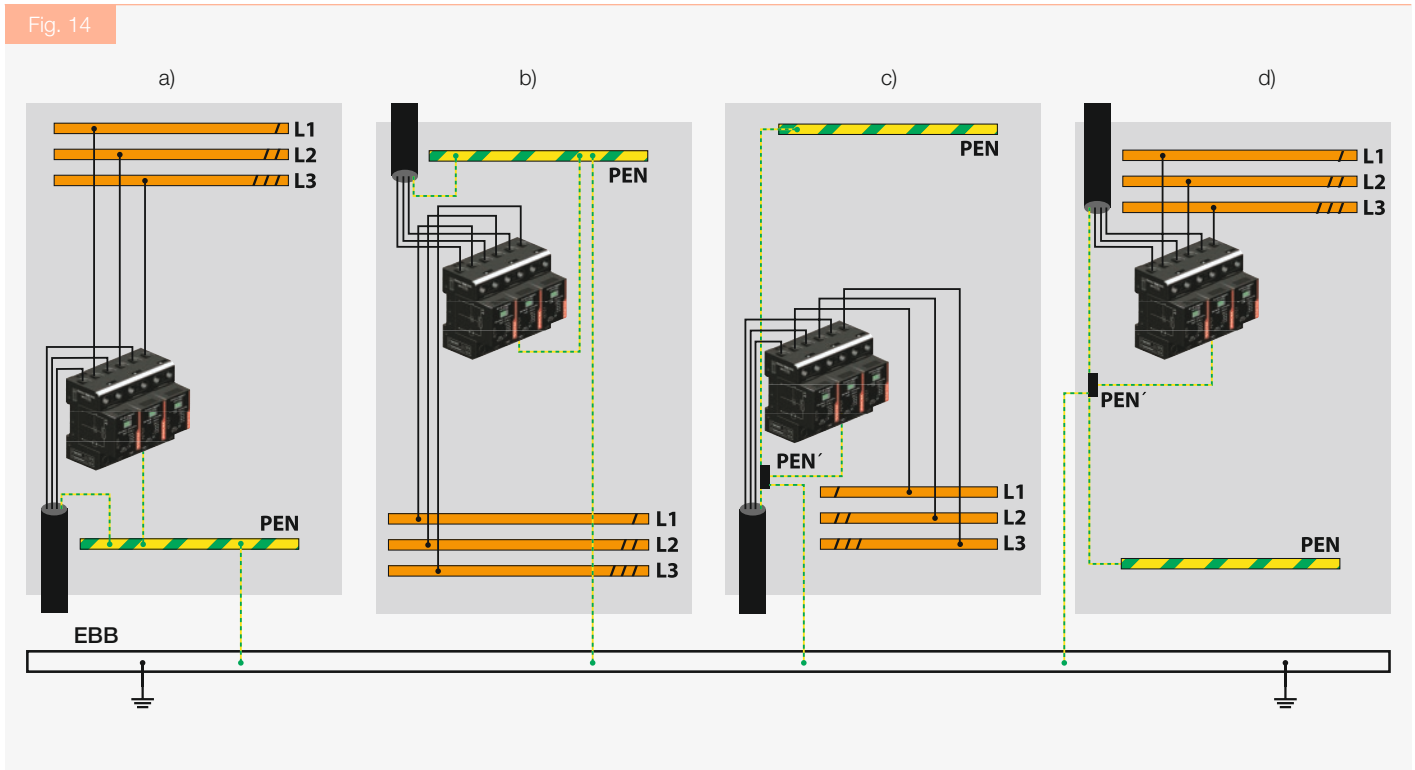

The next figure shows the practical implementation of the c) option displayed in Fig. 14.

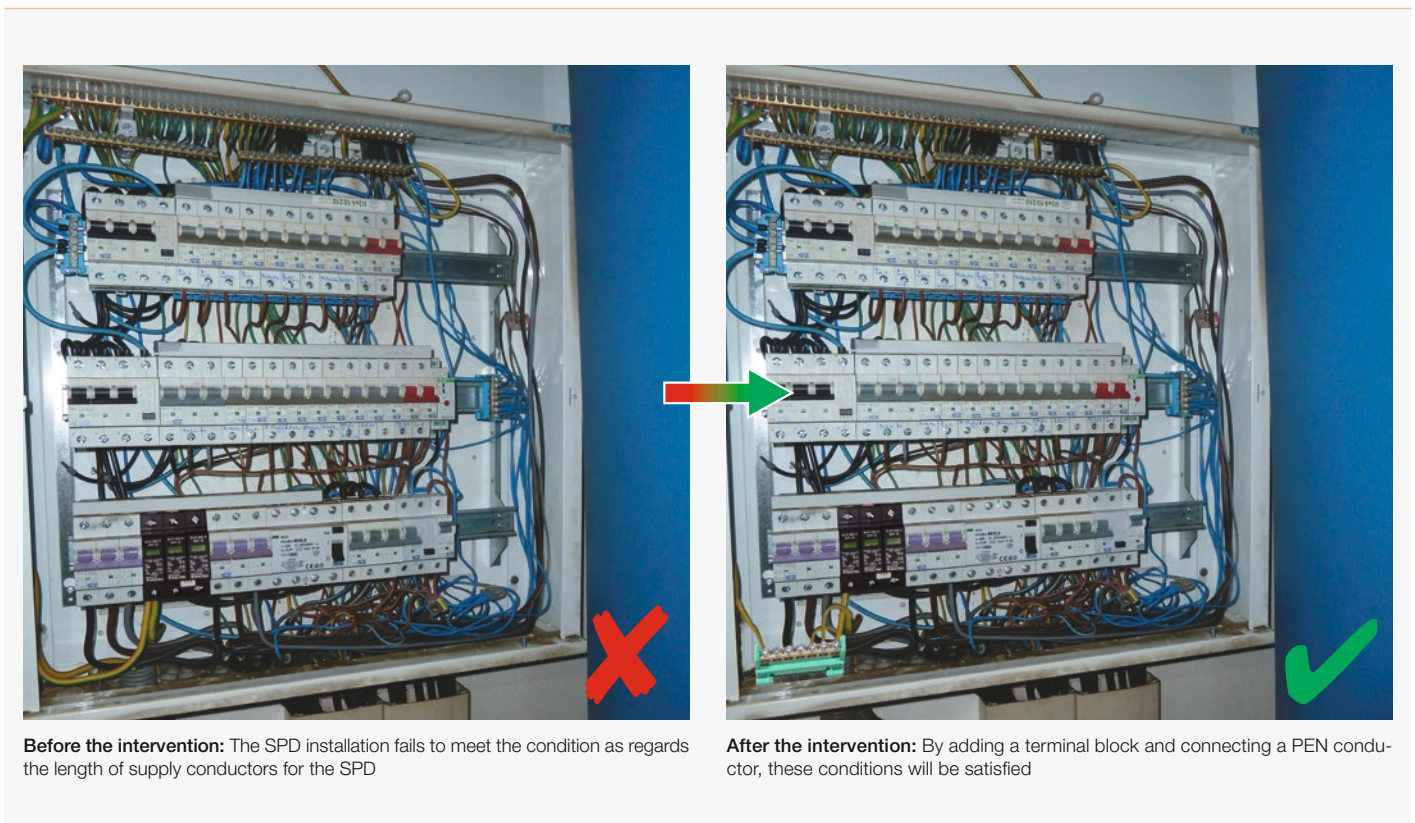

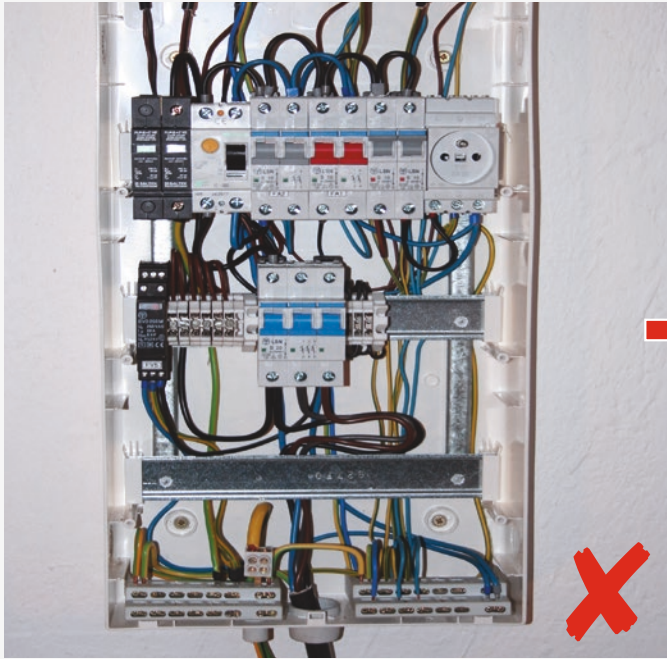

Before the intervention: The SPD installation fails to meet the condition as regards the length of supply conductors for the SPD and also the SPD connection for the TN-S system

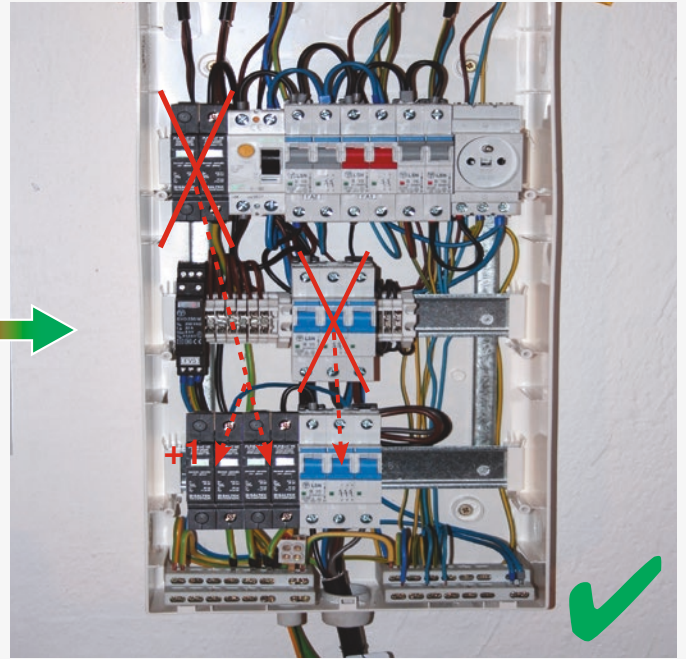

After the intervention: By relocating the circuit breaker and the SPD, the conditions will be satisfied; and by adding one more SPD the N conductor will also be protected.

Principle 3 – loops

To minimize the overvoltage induced in a loop and to considerably reduce the effects of such overvoltages on other equipment connected in the distribution board, the surface of the

loop consisting of the L, N and PE conductors must be kept as small as possible. The principle of minimizing the loop is shown in Fig. 14 and the following examples.

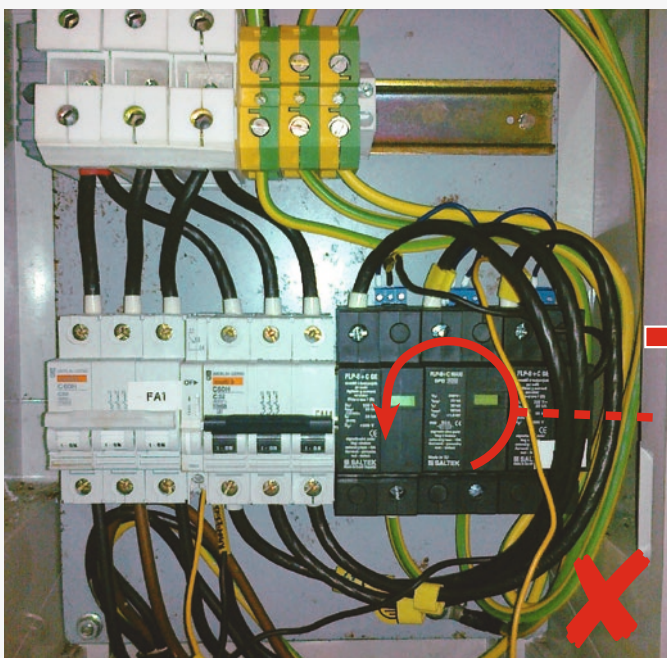

Before the intervention

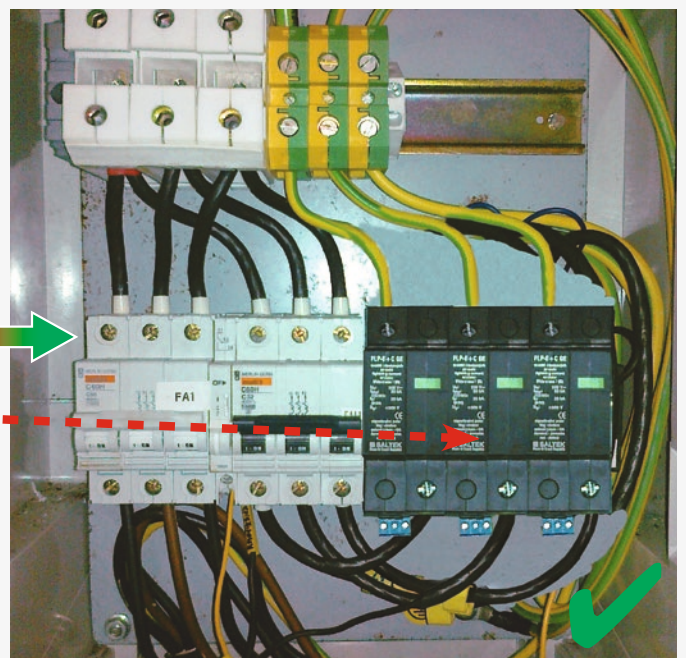

After the intervention: By turning the SPD, the hardwiring in the distribution board will be better arranged and, at the same time, the condition from IEC 61643-12/2008 (CLC/TS 61643-12/2009) concerning loops will be satisfied



Before the intervention

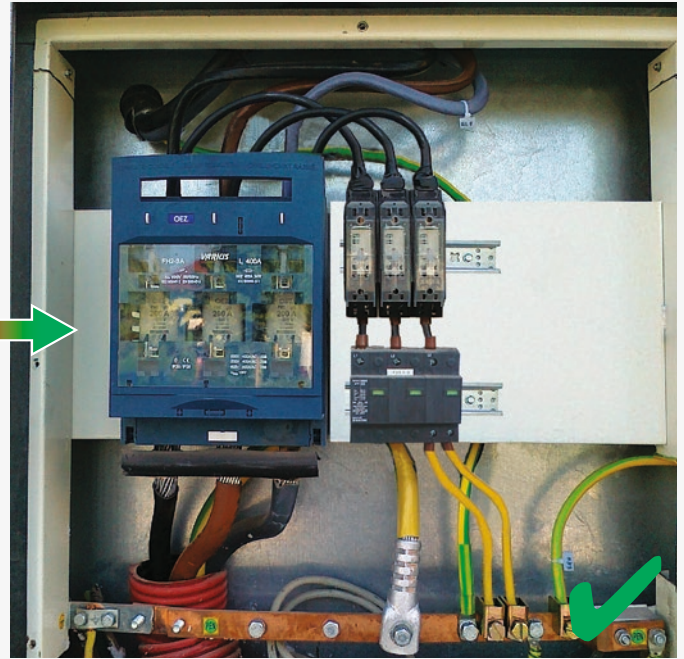

After the intervention: By relocating the SPD, the hardwiring in the distribution board will be better arranged, the condition concerning loops specified in IEC 61643-12/2008 (CLC/TS 61643-12/2009) will be satisfied and, at the same time, the condition stipulating the length of supply conductors for the SPD will be met as well

Principle 4 – conductor routing in the distribution board

When routing the conductors in the distribution board it is always necessary to separate protected („clean“) from unprotected („dirty“) conductors. To minimise the bonding between the different types of conductors („clean“ and „dirty“), it is essential to keep the distance between them as great as possible (over 30 cm). If such a distance is impossible

to observe, a protective partition should be placed between them, see Fig. 15.

If you cannot avoid crossing of protected and unprotected conductors, the crossing should be made at a right angle to prevent induction of interference pulses in the protected conductors, as shown in Fig. 16.

Fig. 15

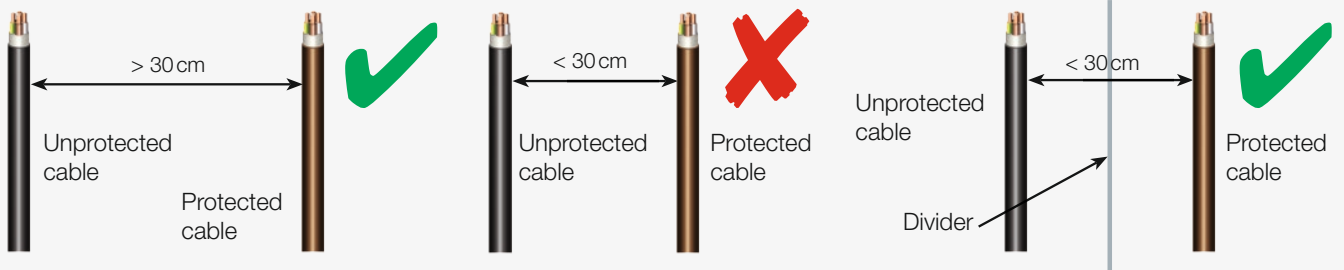
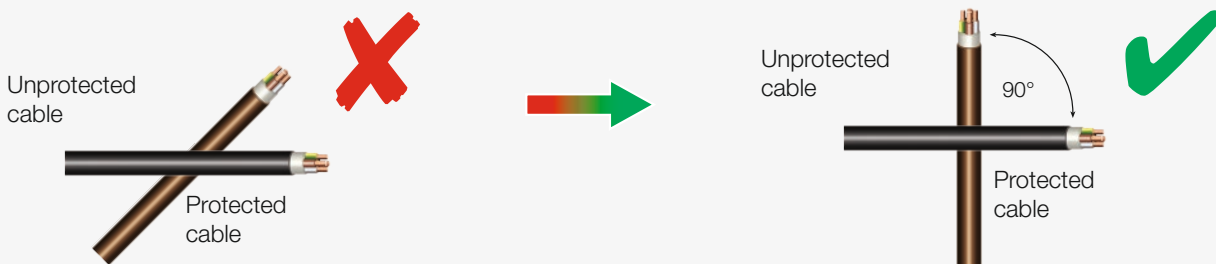

Fig. 16



Coordination of SALTEK SPDs Rules

To achieve correct operation of individual SPD protection levels, specific distances should be observed between them. A general solution is shown in Fig. 17 and Fig. 19. Fig. 18 shows incorrect coordination between the individual SPDs.

Should it be impossible to observe the coordination distances between the specific protection levels, the distance can be extended using coordination RTO impedances. These coordination

impedances must be sized to the current flowing through the line. This can be established from the value of the circuit protection.

Since the usage of RTOs appears rather problematic for higher currents of long duration when the distances between the respective stages are not adhered to, it is the reason why coordinated SPDs of type 1 with the corresponding SPD type 2 are used.

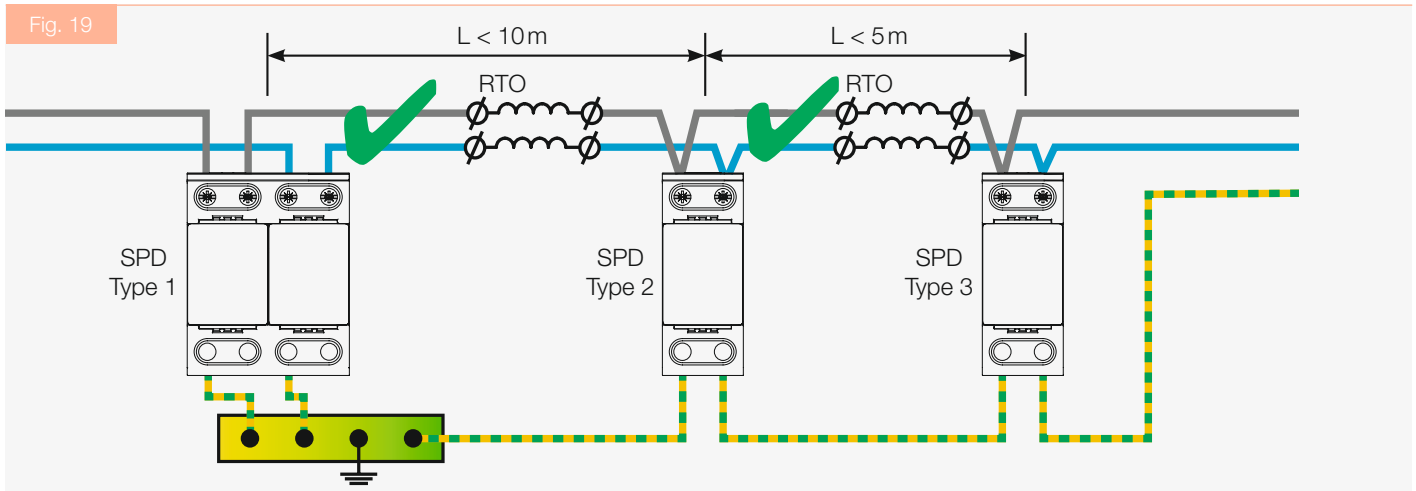
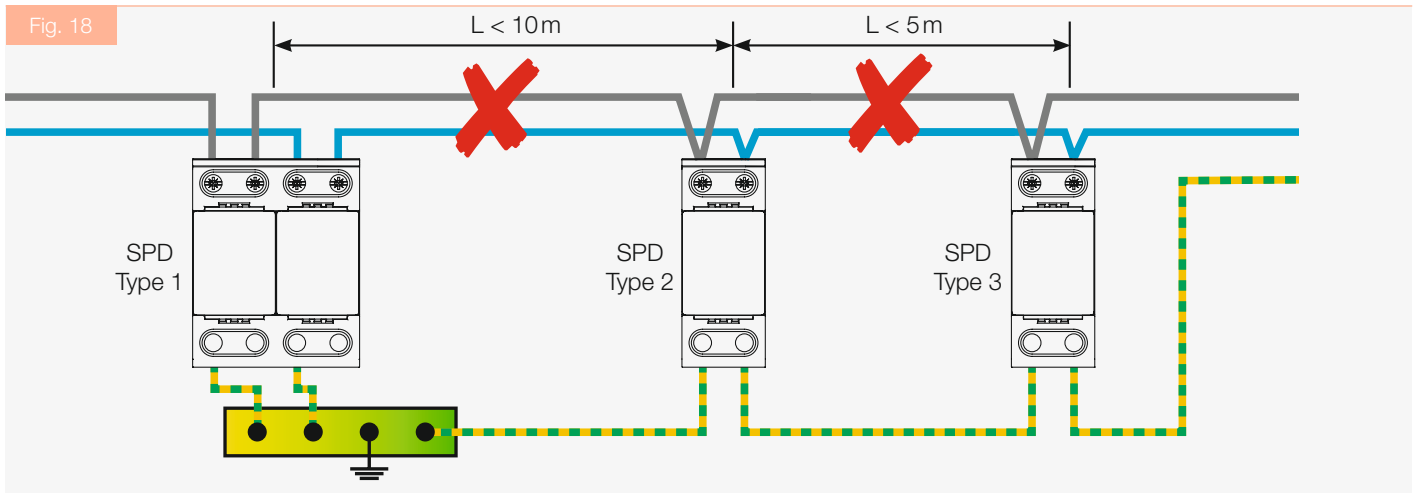
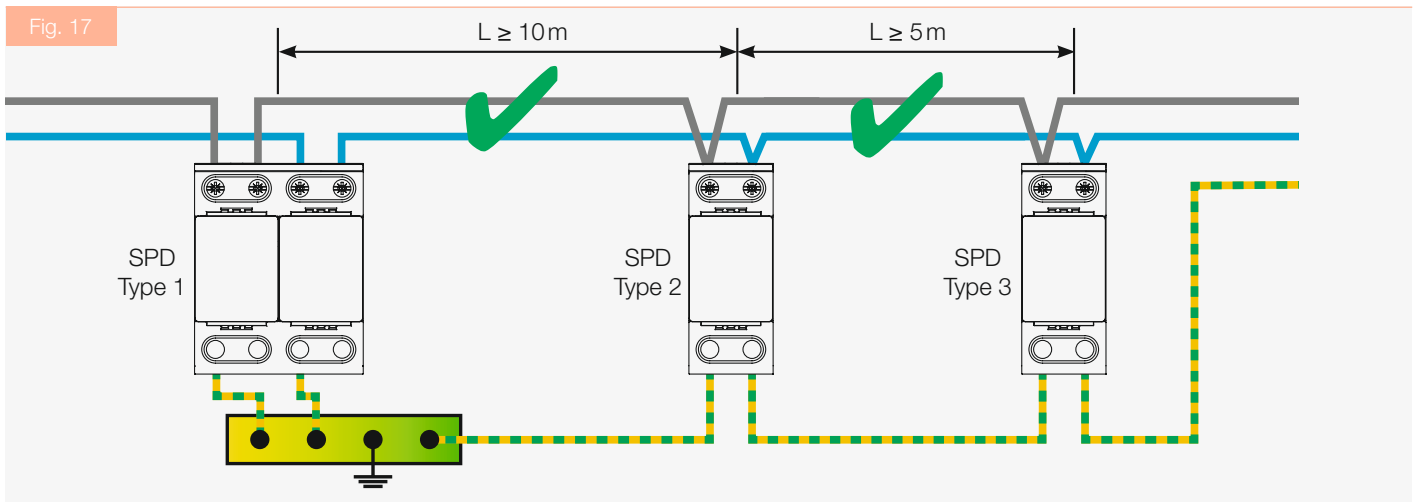

See following figures for coordination of specific SPD type 1 and SPD type 2 by Saltek. If lightning arrester FLP-SG50 V/1 is used as an SPD type 1 and SLP-275 V is used as an SPD type 2, it will not be necessary to keep the distance between them in excess of 10 m since they are mutually coordinated and can be mounted next to each other (see Fig. 20).

the distance between this SPD and the next one exceeds 10 m, an SPD type 2 should be located behind the SPD type 1+2, e.g., SLP-275 V (see Fig. 21).

If the distance between this SPD and the next one is less than 10 m, you will not need to install an SPD type 2 downstream of the SPD type 1+2.

If, for example, FLP-B+C MAXI V is installed as an SPD type 1, which is an SPD type 1+2 with $U_p < 1.5$ kV and

The same applies only if an SPD type 2 is used instead of an SPD type 1+2 (see Fig. 22).

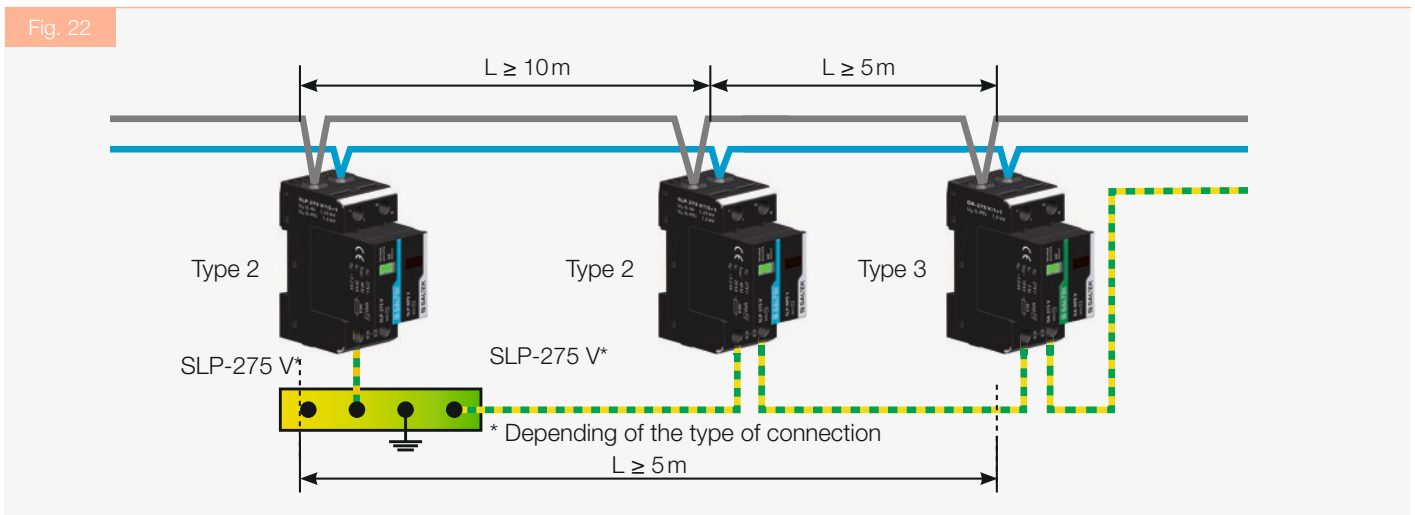
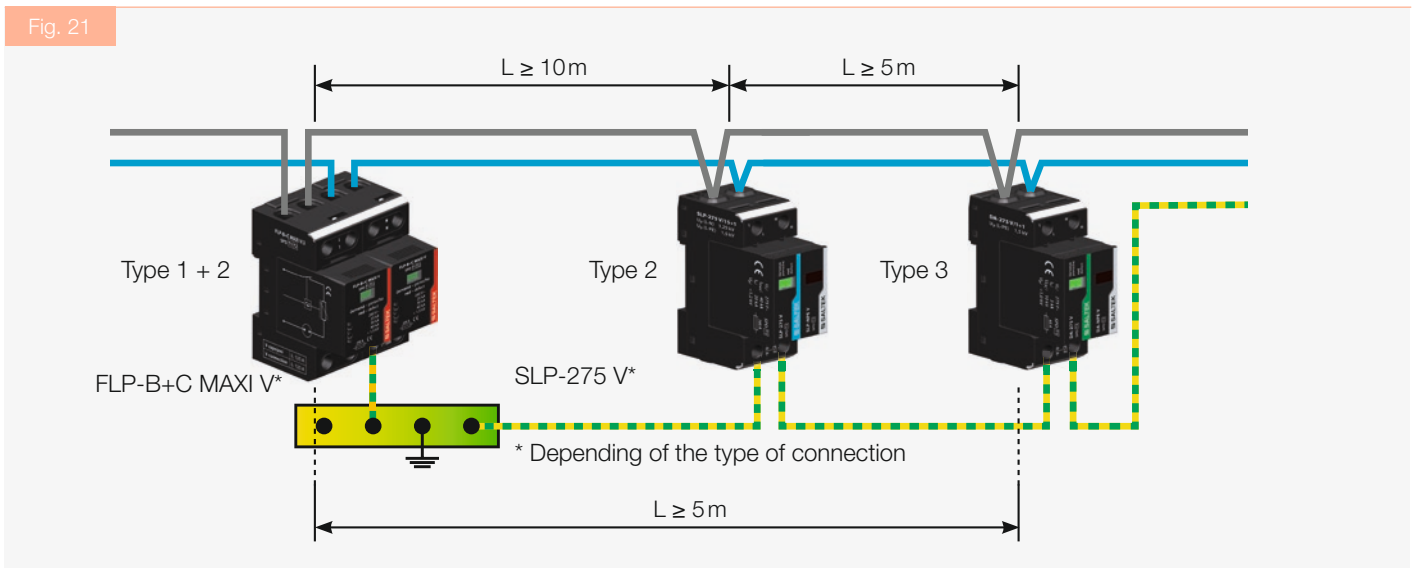
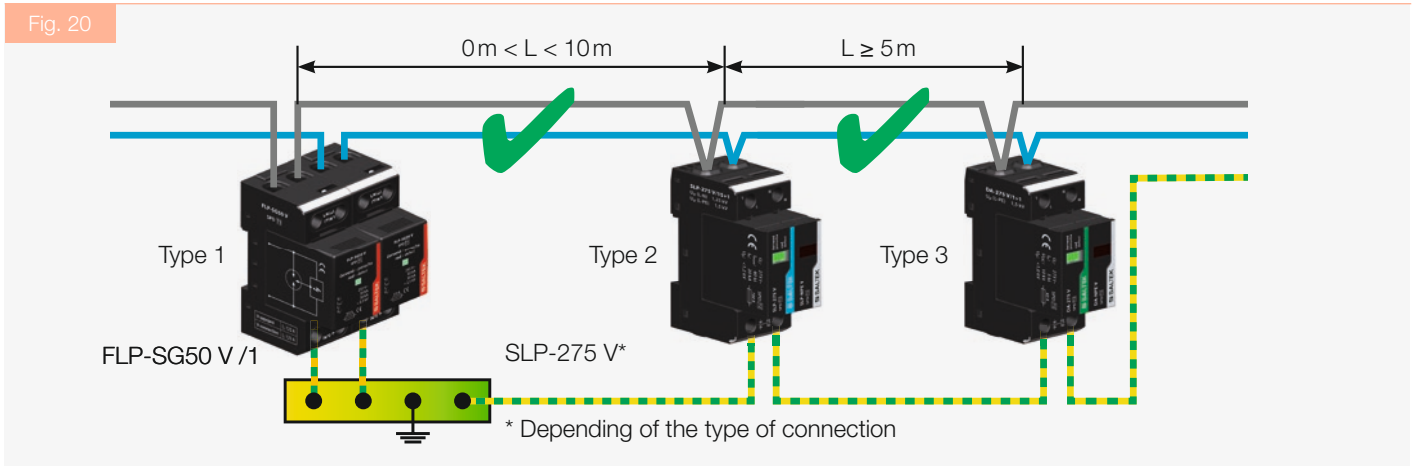

Also for correct operation of the stages of the SPD type 2 and SPD type 3, minimum distances need to be adhered to. Again, a general design is shown in *Fig. 17* and *Fig. 19*, and wrong coordination is shown in *Fig. 18*. Should no coordination distance can be maintained between SPD type 2 and SPD type 3, the distance can be again increased using

the RTO coordination impedances, see *Fig. 19*. The coordination impedances need to be rated to the line current.

See following table for coordination with minimum distance of selected SPDs by SALTEK

SPD type 1+2	SPD type 2	SPD type 3
FLP-B+C MAXI V/1	SLP-275 V/1	DA-275 V/1+1
FLP-B+C MAXI V/3	SLP-275 V/3	DA-275 V/3+1
FLP-B+C MAXI V/1		DA-275 V/1+1
FLP-B+C MAXI V/3		DA-275 V/3+1
FLP-B+C MAXI V/1	SLP-275 V/2	DA-275 V/1+1
FLP-B+C MAXI V/3	SLP-275 V/4	DA-275 V/3+1
FLP-B+C MAXI V/1	SLP-275 V/1+1	DA-275 V/1+1
FLP-B+C MAXI V/3	SLP-275 V/3+1	DA-275 V/3+1
FLP-B+C MAXI V/2	SLP-275 V/2	DA-275 V/1+1
FLP-B+C MAXI V/4	SLP-275 V/4	DA-275 V/3+1
FLP-B+C MAXI V/1+1		DA-275 V/1+1
FLP-B+C MAXI V/3+1		DA-275 V/3+1
FLP-B+C MAXI V/1+1	SLP-275 V/2	DA-275 V/1+1
FLP-B+C MAXI V/3+1	SLP-275 V/4	DA-275 V/3+1
FLP-B+C MAXI V/1+1	SLP-275 V/1+1	DA-275 V/1+1
FLP-B+C MAXI V/3+1	SLP-275 V/3+1	DA-275 V/3+1
FLP-B+C MAXI V/1	SLP-275 V/1	
FLP-B+C MAXI V/3	SLP-275 V/3	
	SLP-275 V/1	DA-275 V/1+1
	SLP-275 V/3	DA-275 V/3+1
	SLP-275 V/2	DA-275 V/1+1
	SLP-275 V/4	DA-275 V/3+1
FLP-B+C MAXI V/1+1	SLP-275 V/2	
FLP-B+C MAXI V/3+1	SLP-275 V/4	
FLP-B+C MAXI V/1+1	SLP-275 V/1+1	
FLP-B+C MAXI V/3+1	SLP-275 V/3+1	
	SLP-275 V/1+1	DA-275 V/1+1
	SLP-275 V/3+1	DA-275 V/3+1

Relation between distance and selection of SPD

Since there are situations in practice where the equipment to be protected is connected directly from the main distribution board and the technology distribution board finds itself usually at a distance of tens of meters, it is advisable to install an SPD in the technology distribution board to cope with over-voltage as well as different earth potentials that might occur there, particularly if the earthing (equipotential bonding) is

not completely all the way through. Consequently, an SPD type 1+2, featuring a diverting ability of $I_n = 30 \text{ kA}$ ($8/20 \mu\text{s}$), should be installed in the position of the SPD type 2, whose diverting ability is $I_n = 20 \text{ kA}$ ($8/20 \mu\text{s}$), to work I_n in this case as a strong SPD type 2 (see Fig. 23-24 and Fig. 25-26). For more information see the table "SALTEK SPD applications in LV distribution systems", pages 32-33.

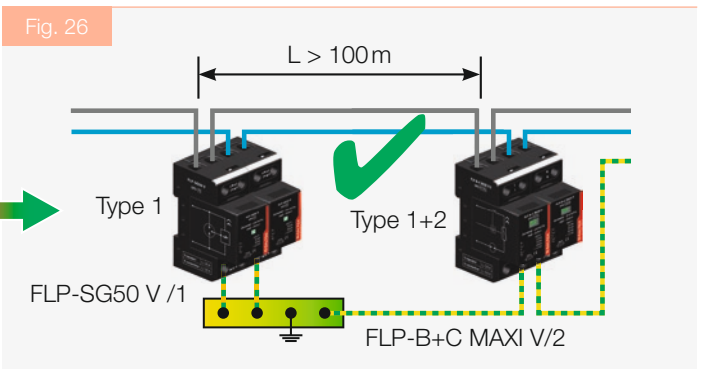
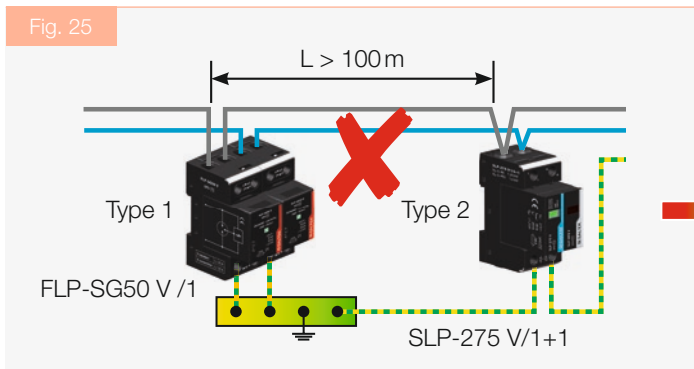
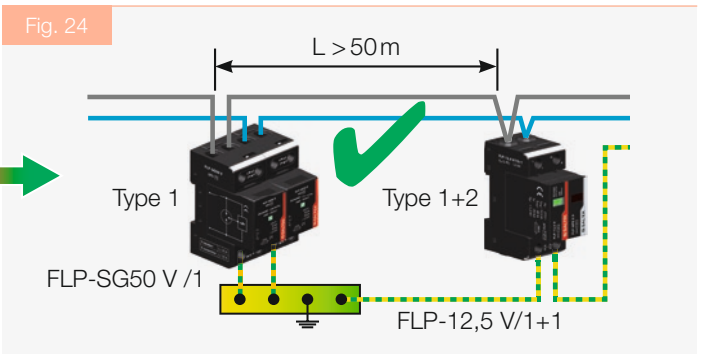
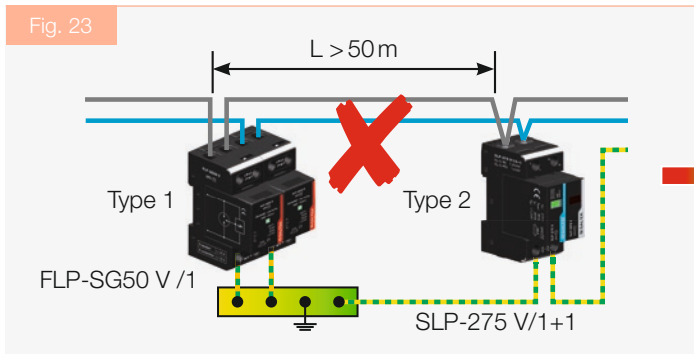

Ranging the SPDs with reference to U_p

In series connection of SPDs with different level, attention should be valid both to their mutual distance (reflection factor effect, see below) and their U_p (protection voltage level).

The series connection of SPD is shown in the following figures (Fig. 27-28 and Fig. 29-30).

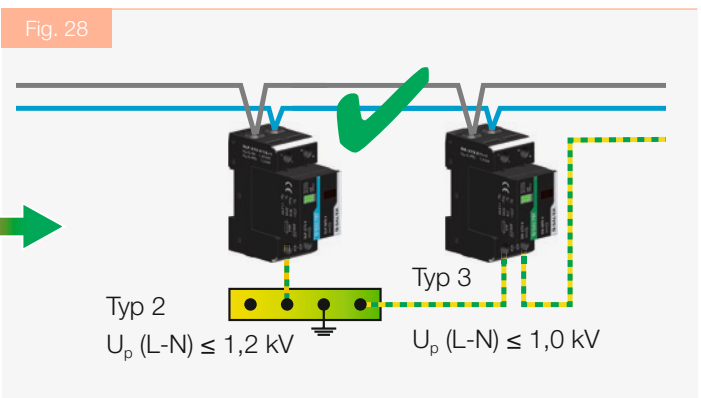
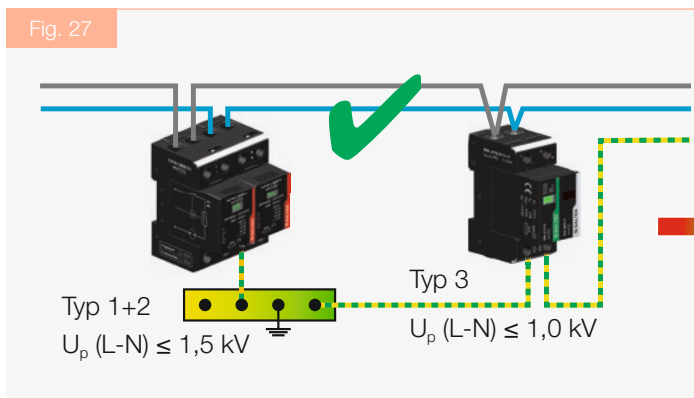

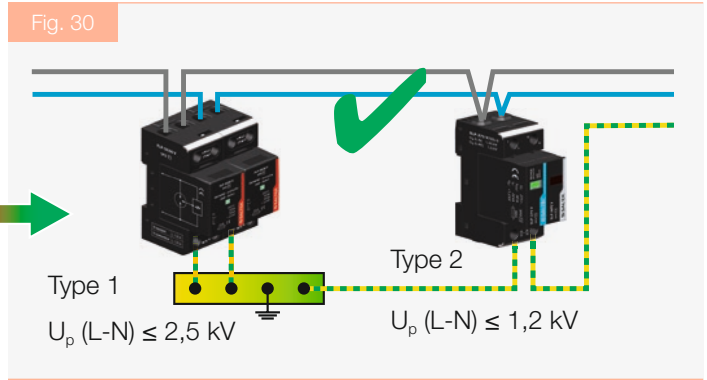
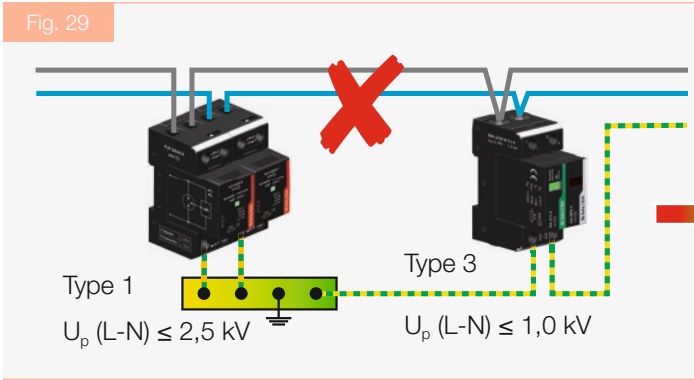

Protective distance

To protect specific equipment, an SPD should be installed as close as possible to the protected equipment. If the distances between the SPDs or that between the SPD and the protected equipment are too long, voltages caused by oscillation phenomena may appear on the line which can destroy either the connected equipment or cause the breakdown of power line insulation. These oscillations can

even double the U_p protection voltage level. The doubling effect occurs if the equipment is disconnected inside or its input impedance is high. If the distance between the SPD and the protected equipment is $L \leq 10 \text{ m}$, the oscillations disturbing signals need not be taken into consideration. If the distance is great ($L \gg 10 \text{ m}$), remember to install an additional SPD (see Fig. 31–32 and Fig. 33–34).

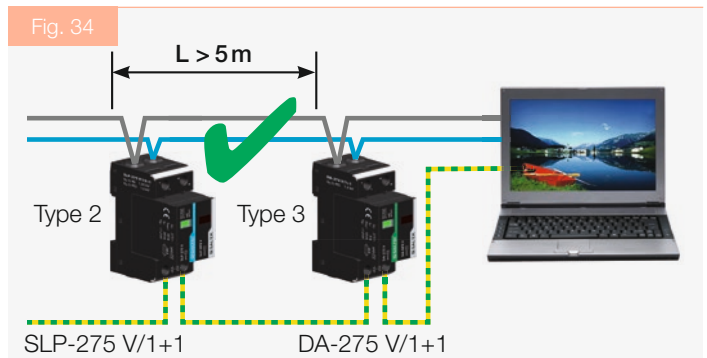
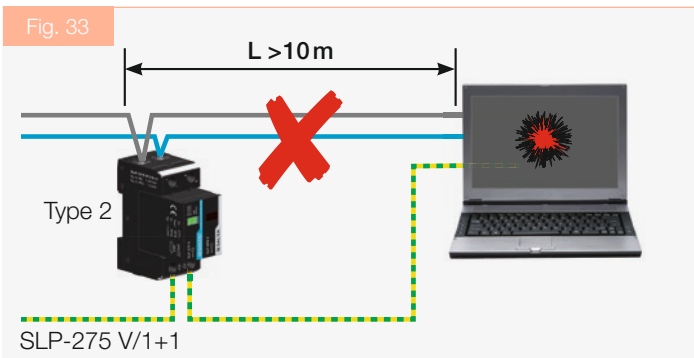
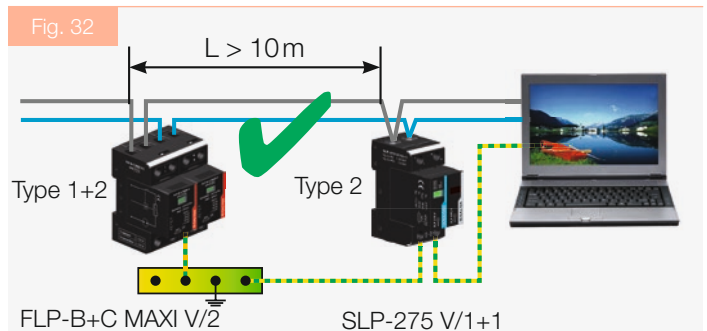
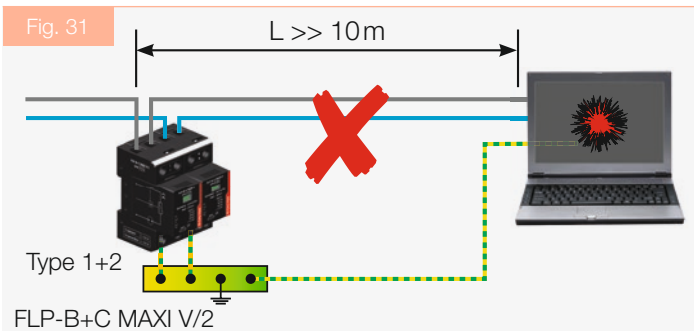

In the practice, the protective distance of the SPD always decreases due to voltages induced by lightning currents or the switching of burdens connected in the loop circuit. This is why the distance between an SPD and the technology should never exceed 5 m.

This is of particular importance in protecting highly sensitive equipment, such as electronic security systems, electronic fire signalling systems, PLC and other processor-controlled technology that is also prone to induced switching over-

voltage. Such overvoltage with a very short duration (in μs) and a small pulse amplitude (hundreds of volts) would pass up to the equipment, which maybe will not destroy it but may cause the processor to freeze or damage or erase memory chips or impair the functionality of the equipment. Hence, an SPD type 3 with a RFI filter, able to cope with this problem, should be installed in these cases. An example of the connection of an SPD type 3 with a RFI filter is shown in Fig. 35 and Fig. 36.

Fig. 35

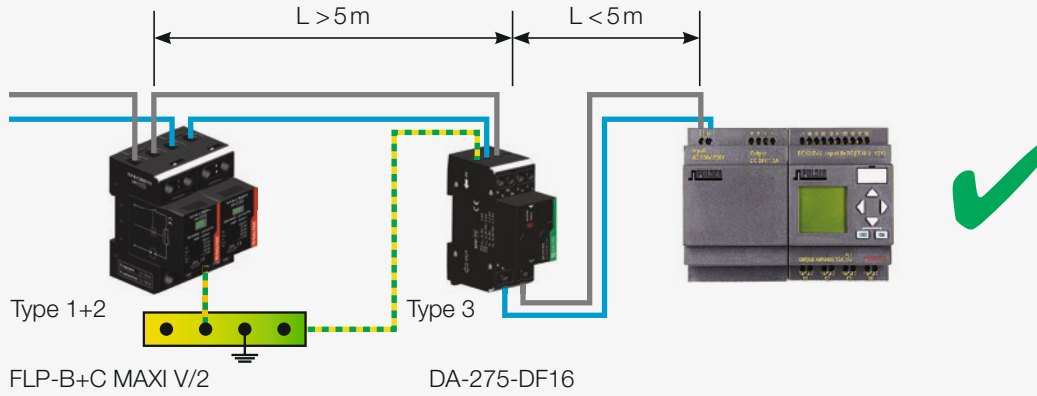
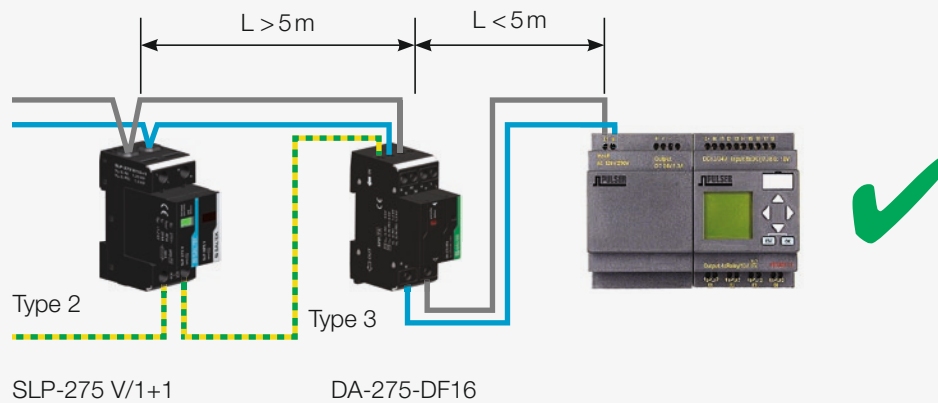

Fig. 36



Socket circuits with SPD type 3

Consideration should be taken regarding socket circuits, which are usually very long and are used in different situations. The protective distance of an SPD type 3 in cabled socket circuits amounts to 5 m, at maximum, as shown in Fig. 38.

To ensure correct functioning of an SPD type 3, both protection levels – SPD type 1 and SPD type 2 – should be mounted upstream.

Socket circuitry featuring all sockets either with integrated SPD type 3 protection or available with SPD type 3 protection for additional installation (see Fig. 37), is always used in heavily disturbed environments, or places with a larger number of electrical appliances installed. Laboratories are a typical example of such environment.

Fig. 37

A socket with integrated SPD type 3



In order to reduce the number of SPD type 3 in the socket circuitry, protective distances between the SPDs type 3 of less than 5 m are used as standard. In these cases it is not necessary to equip all sockets with SPD type 3 protection. The basic principle to follow in this method of installing an SPD type 3 is that the SPD must always be installed at the first socket in the socket circuit; the protective distance principle for SPD type 3, as shown in Fig. 38, can be applied only after that. Fig. 39 shows an example of incorrect application of the protective distance. The principle of protective distance cannot be applied to situations where one side of the wall features a socket circuit with, for example, a down conductor bar or an unprotected ascending LV line situated on the other side of the wall. All sockets installed at this place should be provided with an SPD type 3, as shown in Fig. 40 and Fig. 41.

plied only after that. Fig. 39 shows an example of incorrect application of the protective distance. The principle of protective distance cannot be applied to situations where one side of the wall features a socket circuit with, for example, a down conductor bar or an unprotected ascending LV line situated on the other side of the wall. All sockets installed at this place should be provided with an SPD type 3, as shown in Fig. 40 and Fig. 41.

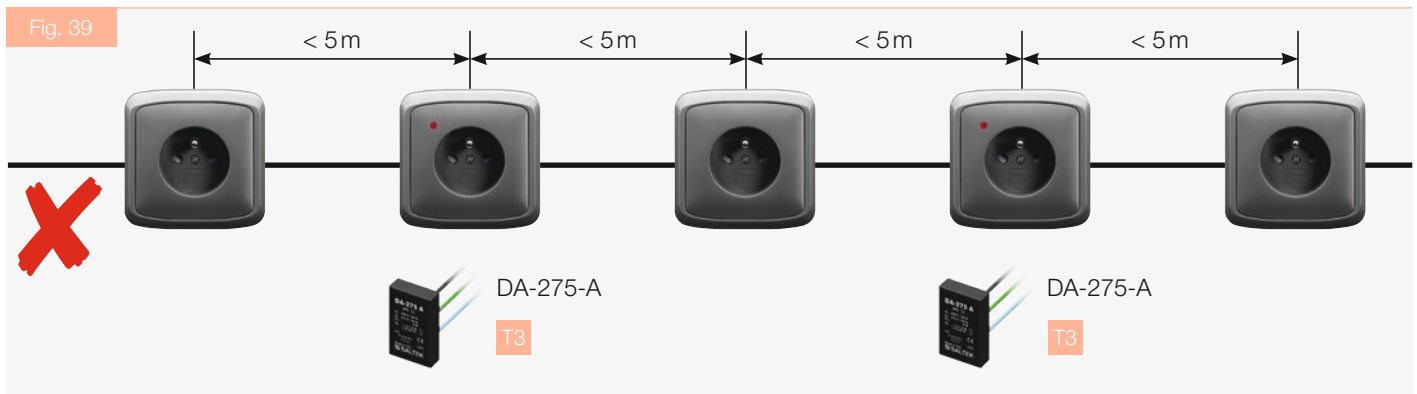
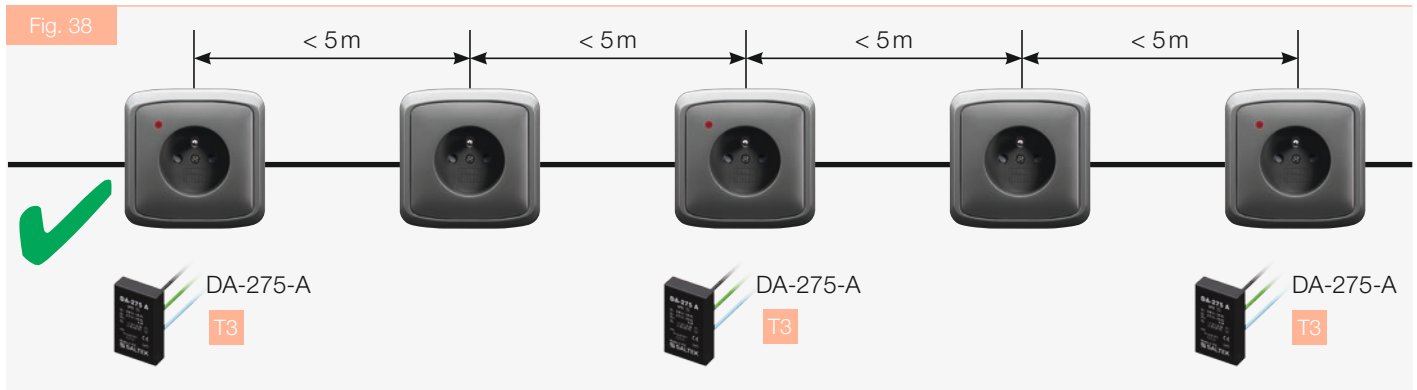

If this principle is not observed, the problem located at the LV line bar will manifest itself in the socket circuit and will damage the equipment connected to the specific socket. Administrative buildings feature a great number of socket circuits with many sockets. To reduce the number of SPDs in such cases, not only the protective distance for the SPD

type 3 is used, but also so-called installations in groups, as shown in the following examples. If distances between individual groups exceed 5 m, as shown in Fig. 42, the passage socket group must be provided with an SPD type 3 at the first and last socket.

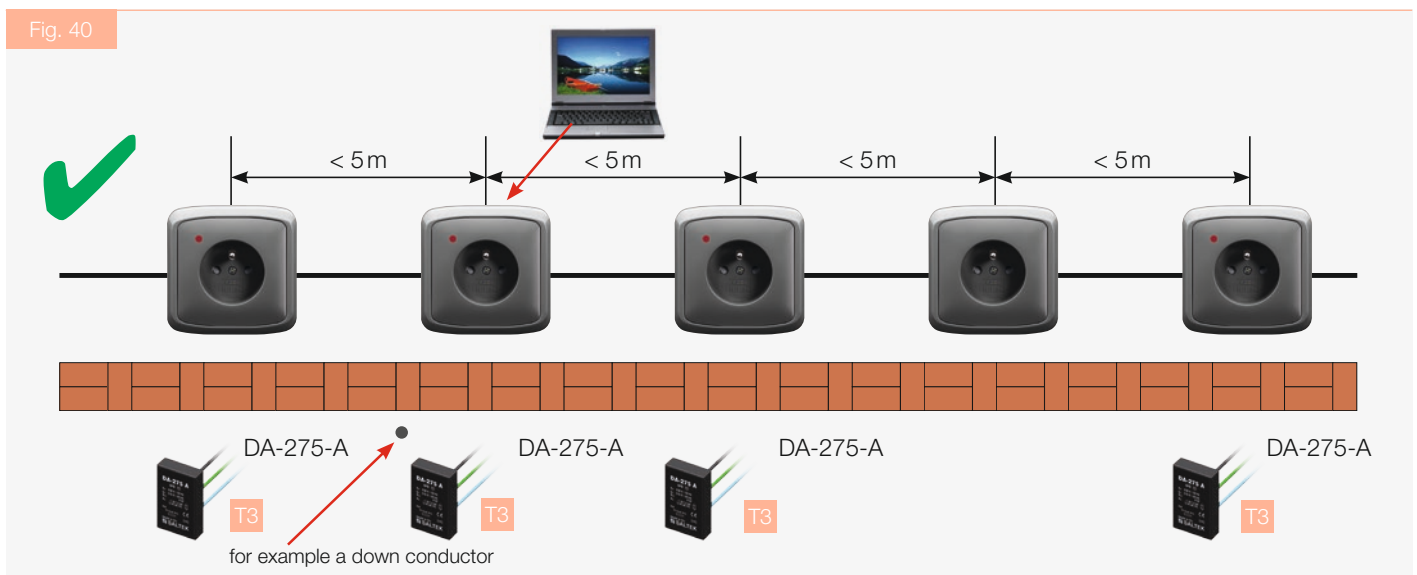

Fig. 41

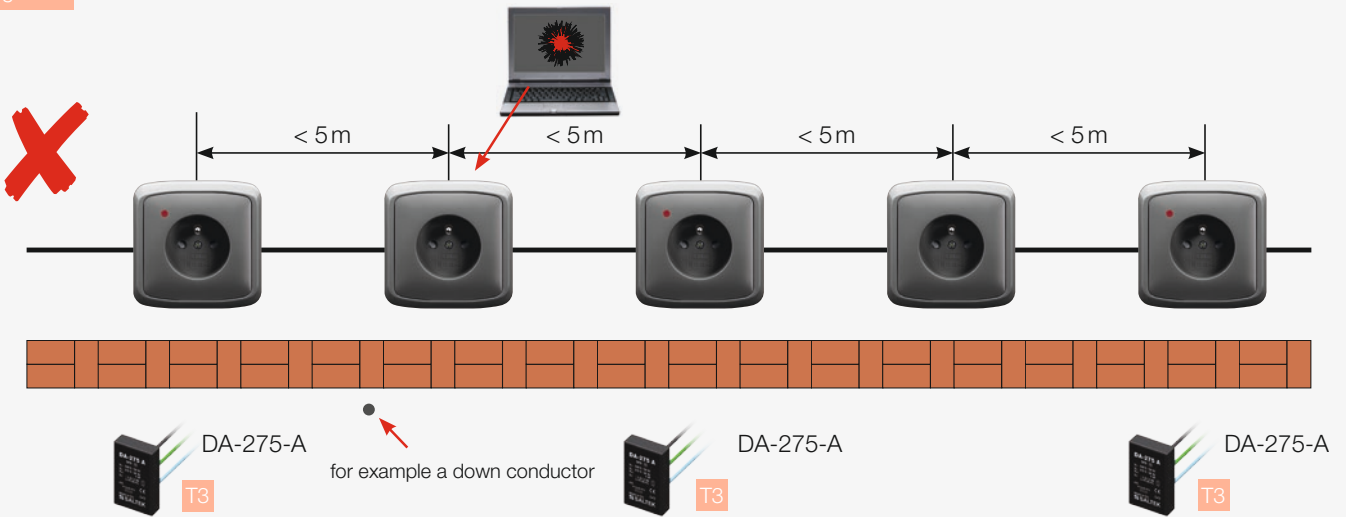

Fig. 42

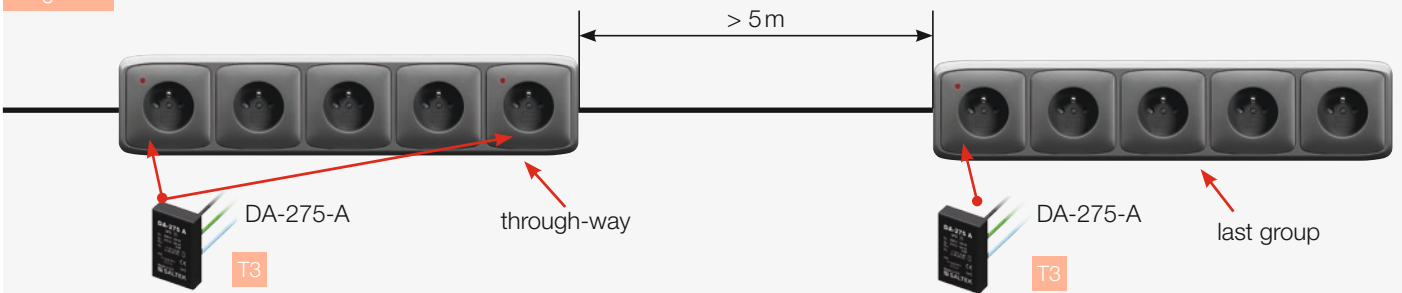

Fig. 43

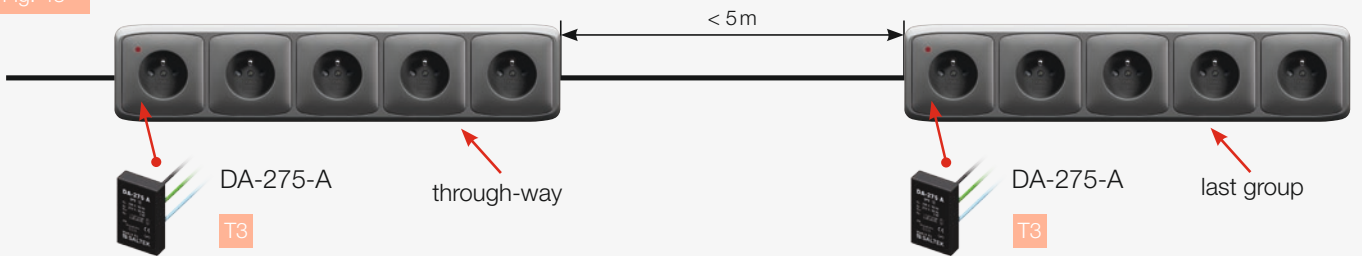
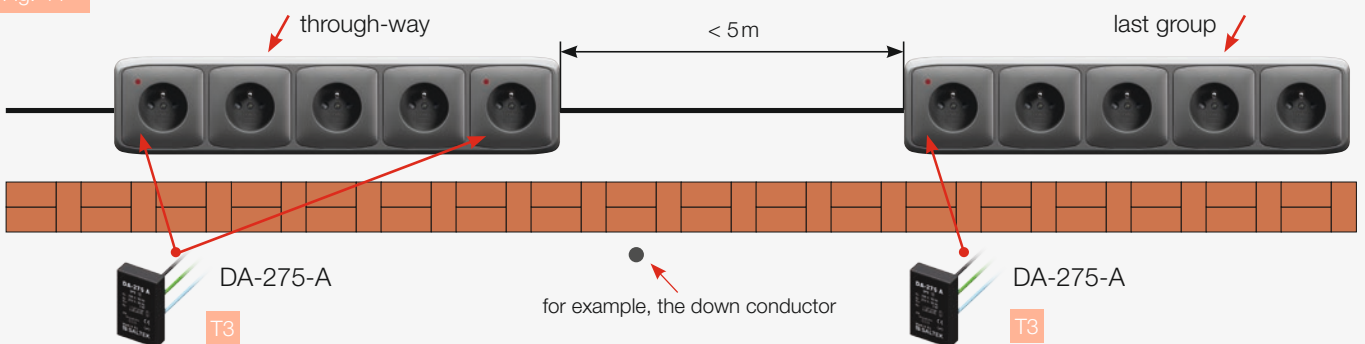

Fig. 44



If the group is not a through-way group, an SPD type 3 should always be installed at the first socket. Should the distance between individual socket groups be less than 5 m, then the property of the SPD protective distance can be used and the no an SPD type 3 will be mounted on the through-way group - see Fig. 43. The principle of protec-

tive distance cannot be applied in situations where the distance between two groups is less than 5 m, and, for example, a down lead or an unprotected LV line is located on the other side of the wall. It is necessary in this case that the last socket of the through-way group be provided with an SPD type 3. This option is shown in Fig. 44.

SALTEK® SPD applications in LV distribution systems

Type of structure	system	main distribution board (in the structure)	sub-distribution board (in the same structure)	end consumer
Family houses, administrative buildings, technologic units, industrial structures	3-ph. TN-C	FLP-B+C MAXI VS/3, FLP-B+C MAXI V/3 FLP-25-T1-VS/3, FLP-25-T1-V/3	distance > 10 m SLP-275 V/3(S)	distance > 5 m
			distance > 50 m FLP-12.5 V/3(S)	overvoltage protection to DIN rail: DA-275 V/1(S)+1 (up to 63 A) DA-275 V/3(S)+1 (up to 63 A) DA-275-DJxx (up to 25 A)
			distance > 100 m FLP-B+C MAXI V/3, FLP-B+C MAXI VS/3	
		FLP-25-T1-VS/3, FLP-25-T1-V/3	distance < 10 m SLP-275 V/3(S)	
		FLP-B+C MAXI VS/3, FLP-B+C MAXI V/3 FLP-25-T1-VS/3 + SLP-275 V/3 S FLP-25-T1-V/3 + SLP-275 V/3 (also with terminals to the equipment)	distance > 10 m SLP-275 V/3(S)	overvoltage protection to a DIN rail with a RFI filter: DA-275-DFx-(S) (x = 2, 6, 10, 16 A) DA-275 DF 25 for 25 A DA-275-DFixx (x = 1, 6, 10, 16 A)
		distance > 50 m FLP-12.5 V/3(S)		
	3-ph. TN-S	FLP-B+C MAXI VS/4, FLP-B+C MAXI V/4 FLP-25-T1-VS/4, FLP-25-T1-V/4	distance > 10 m SLP-275 V/4(S)	RACK-PROTECTOR multiple sockets to 19"stands
			distance > 50 m FLP-12.5 V/4(S)	
			distance > 100 m FLP-B+C MAXI V/4, FLP-B+C MAXI VS/4	CZ-275-A, DA-275 CZS DA-275-A, DA-275-S
		FLP-25-T1-VS/4, FLP-25-T1-V/4	distance < 10 m SLP-275 V/4(S)	for additional assembly to the sockets and appliances
		FLP-B+C MAXI VS/4, FLP-B+C MAXI V/4 FLP-25-T1-VS/4 + SLP-275 V/4 S FLP-25-T1-V/4 + SLP-275 V/4 (also with terminals to the equipment)	distance > 10 m SLP-275 V/4(S)	sockets with overvoltage protection (ABB)
		distance > 50 m FLP-12.5 V/4(S)		
3-ph. TN-C-S	FLP-B+C MAXI VS/3, FLP-B+C MAXI V/3 FLP-25-T1-VS/3, FLP-25-T1-V/3	distance > 10 m SLP-275 V/4(S)	XX-OVERDRIVE socket adapters	
		distance > 50 m FLP-12.5 V/4(S)		
		distance > 100 m FLP-B+C MAXI V/4, FLP-B+C MAXI VS/4		
	FLP-25-T1-VS/3, FLP-25-T1-V/3	distance < 10 m SLP-275 V/4(S)		
	FLP-B+C MAXI VS/3, FLP-B+C MAXI V/3 FLP-25-T1-VS/3 + SLP-275 V/3 S FLP-25-T1-V/3 + SLP-275 V/3 (also with terminals to the equipment)	distance > 10 m SLP-275 V/4(S)		
	distance > 50 m FLP-12.5 V/4(S)			
Blocks of flats with 12 or more apartments (SPD located in the apart. distr. boards)	3-ph. TN-C		FLP-12.5 V/3(S)	
	3-ph. TN-S		FLP-12.5 V/4(S)	
	3-ph. TN-C-S	division in the apartment distr. board	FLP-12.5 V/3(S)	distance < 5 m place before the overvoltage protection RTO-xx (xx – rated current 16, 35 or 63 A)
	1-ph. TN-C		FLP-B+C MAXI V/1, FLP-B+C MAXI VS/1	
	1-ph. TN-S		FLP-12.5 V/2(S)	
Demanding applications (structures – operations classified at the risk of explosion, chemical plants..., structures of a very high importance)	3-ph. TN-C	3x FLP-SG50 V(S)/1	distance < 10 m 1x SLP-275 V/3(S)	number according to connection
			distance > 10 m SLP-275 V/3(S)	1-phase TN-C 1x RTO-xx
			distance > 50 m FLP-12.5 V/3(S)	1-phase TN-S 2x RTO-xx
		distance > 100 m FLP-B+C MAXI V/3, FLP-B+C MAXI VS/3	3-phase TN-C 3x RTO-xx	
		with terminals to the equipment 3x FLP-SG50 V(S)/1 + 1x SLP-275 V/3(S)	distance > 10 m SLP-275 V/4(S)	3-phase TN-S 4x RTO-xx
		distance > 50 m FLP-12.5 V/4(S)		
	3-ph. TN-S	4x FLP-SG50 V(S)/1	distance < 10 m 1x SLP-275 V/4(S)	
			distance > 10 m SLP-275 V/4(S)	
			distance > 50 m FLP-12.5 V/4(S)	
		distance > 100 m FLP-B+C MAXI V/4, FLP-B+C MAXI VS/4		
		with terminals to the equipment 4x FLP-SG50 V(S)/1 + 1x SLP-275 V/4(S)	distance > 10 m SLP-275 V/4(S)	
		distance > 50 m FLP-12.5 V/4(S)		
3-ph. TN-C-S	division in the main distribution board 3x FLP-SG50 V(S)/1	distance < 10 m 1x SLP-275 V/4(S)		
		distance > 10 m SLP-275 V/4(S)		
		distance > 50 m FLP-12.5 V/4(S)		
	with terminals to the equipment 3x FLP-SG50 V(S)/1 + 1x SLP-275 V/4(S)	distance > 100 m FLP-B+C MAXI V/4, FLP-B+C MAXI VS/4		
	distance > 100 m FLP-B+C MAXI V/4, FLP-B+C MAXI VS/4			
	distance > 100 m FLP-B+C MAXI V/4, FLP-B+C MAXI VS/4			

SALTEK® SPD applications in LV distribution systems

Type of structure	system	main distribution board (in the structure)	sub-distribution board (in the same structure)	end consumer	
Structures equipped with ESE (active down conductor)	3-ph. TN-C	3x FLP-SG50 V(S)/1	distance > 10 m SLP-275 V/3(S)	distance > 5 m	
			distance > 50 m FLP-12.5 V/3(S)	overvoltage protection to DIN rail: DA-275 V/1(S)+1 (up to 63 A) DA-275 V/3(S)+1 (up to 63 A)	
			distance > 100 m FLP-B+C MAXI V/3, FLP-B+C MAXI VS/3	DA-275-DJxx (up to 25 A)	
		3x FLP-SG50 V(S)/1	distance < 10 m SLP-275 V/3(S)	Overvoltage protection to DIN rail with RFI filter: DA-275-DFx-(S) (x = 2, 6, 10, 16 A) DA-275 DF 25 pro 25 A DA-275-DFixx (x = 1, 6, 10, 16 A)	
			also with terminals to the equipment 3x FLP-SG50 V(S)/1 + SLP-275 V/3(S)	distance > 10 m SLP-275 V/3(S)	
			distance > 50 m FLP-12.5 V/3(S)		
	3-ph. TN-S	4x FLP-SG50 V(S)/1	distance > 100 m FLP-B+C MAXI V/3, FLP-B+C MAXI VS/3	RACK-PROTECTOR multiple sockets for 19"stands	
			distance > 10 m SLP-275 V/4(S)	CZ-275-A, DA-275 CZS DA-275-A, DA-275-S For additional mounting to sockets and appliances	
			distance > 50 m FLP-12.5 V/4(S)	Sockets with overvoltage protection (ABB)	
		4x FLP-SG50 V(S)/1	distance < 10 m SLP-275 V/4(S)	XX-OVERDRIVE Socket adapters	
			also with terminals to the equipment 4x FLP-SG50 V(S)/1 + SLP-275 V/4(S)	distance > 10 m SLP-275 V/4(S)	
			distance > 50 m FLP-12.5 V/4(S)		
3-ph. TN-C-S	3x FLP-SG50 V(S)/1	distance > 100 m FLP-B+C MAXI V/4, FLP-B+C MAXI VS/4			
		distance > 10 m SLP-275 V/4(S)			
		distance > 50 m FLP-12.5 V/4(S)			
	3x FLP-SG50 V(S)/1	distance < 10 m SLP-275 V/4(S)			
		also with terminals to the equipment 3x FLP-SG50 V(S)/1 + SLP-275 V/3(S)	distance > 10 m SLP-275 V/4(S)		
		distance > 50 m FLP-12.5 V/4(S)			
Technology with 1-phase connection	1-ph. TN-C	FLP-SG50 V(S)/1	distance < 10 m SLP-275 V/1(S)	distance < 5 m SPD back-up RTO-xx (xx – rated current 16, 35 or 63 A)	
			with terminals to the equipment FLP-SG50 V(S)/1 + SLP-275 V/1(S)	distance > 10 m SLP-275 V/1(S)	number according to connection
			distance > 50 m FLP-12.5 V/1(S)		
		2x FLP-SG50 V(S)/1	distance > 100 m FLP-B+C MAXI V/1, FLP-B+C MAXI VS/1		
			1-ph. TN-S	distance < 10 m 1x SLP-275 V/2(S)	1-phase TN-C 1x RTO-xx 1-phase TN-S 2x RTO-xx 3-phase TN-C 3x RTO-xx 3-phase TN-S 4x RTO-xx
			with terminals to the equipment 2x FLP-SG50 V(S)/1 + 1x SLP-275 V/2(S)	distance > 10 m 1x SLP-275 V/2(S)	
	1-ph. TN-C-S	Division in the main distribution board FLP-SG50 V(S)/1	distance > 50 m 1x FLP-12.5 V/2(S)		
			distance > 100 m FLP-B+C MAXI V/2, FLP-B+C MAXI VS/2		
			distance < 10 m 1x SLP-275 V/2(S)		
		with terminals to the equipment FLP-SG50 V(S)/1 + SLP-275 V/1(S)	distance > 10 m 1x SLP-275 V/2(S)		
			distance > 50 m 1x FLP-12.5 V/2(S)		
			distance > 100 m FLP-B+C MAXI V/2, FLP-B+C MAXI VS/2		

SPDs connected to LV power supply systems up to 1 000 V

Lightning current arresters (SPD Type 1), spark-gap based

A high-performance spark gap specified for using in LV installations at the boundary of the LPZ 0 and LPZ 1 zones. Surge protection in direct as well as indirect lightning strikes in the hardest application in heavy, chemical and energy industry. Coordination with SPD Type 2 (SLP-275 V) without coupling impedances.

FLP-SG50 V(S)/1



- Pluggable module
- Visual fault signalling
- Module locking
- Optional remote fault signalling (S)
- $U_p \leq 2,5$ kV

Type	Connection	Suitable networks	U_c	I_{imp} (10/350 μ s)	I_n (8/20 μ s)	I_{fi}	Remote signalling	Ordering number
FLP-SG50 V/1	1+0	TN, TT	255 V AC	50 kA	50 kA	50 kA	No	8595090540540
FLP-SG50 VS/1	1+0	TN, TT	255 V AC	50 kA	50 kA	50 kA	Yes	8595090540533

Lightning current arresters (SPD Type 1), serial combination MOV+GDT

Very high-performance lightning current arresters for LV installations at the boundary of the LPZ 0 and LPZ 1 zones or higher. For protection in direct as well as indirect lightning strikes. For using in a variety of installations, for family houses, office and industrial buildings, or in sub-distribution boards of large buildings. Coordination with SPD Type 2 (SLP-275 V) without coupling impedances. **No leakage current. No follow-on current.**

FLP-25-T1-V(S)/...



- Pluggable module
- Visual fault signalling
- Module locking
- Optional remote fault signalling (S)
- $U_p \leq 1,5$ kV

Type	Connection	Suitable networks	U_c	I_{imp} (10/350 μ s)	I_n (8/20 μ s)	I_{max} (8/20 μ s)	Remote signalling	Ordering number
FLP-25-T1-V/3	3+0	TN-C	275 V AC	25 kA	30 kA	60 kA	No	8595090553007
FLP-25-T1-VS/3	3+0	TN-C	275 V AC	25 kA	30 kA	60 kA	Yes	8595090553014
FLP-25-T1-V/3+1	3+1	TT	275 V AC	25 kA	30 kA	60 kA	No	8595090553045
FLP-25-T1-VS/3+1	3+1	TT	275 V AC	25 kA	30 kA	60 kA	Yes	8595090553052
FLP-25-T1-V/4	4+0	TN-S	275 V AC	25 kA	30 kA	60 kA	No	8595090553021
FLP-25-T1-VS/4	4+0	TN-S	275 V AC	25 kA	30 kA	60 kA	Yes	8595090553038

Lightning current arresters (SPD Type 1), spark-gap for N-PE

A spark gap for N-PE with a replaceable module for using in LV installations, at the boundary of the LPZ 0 and LPZ 1 zones. Surge protection in direct as well as indirect lightning strikes. **ATTENTION! Only for wiring between N and PE!**

FLP-A...N VS/NPE



- Pluggable module
- Module locking
- Remote signalling of module presence (S)
- $U_p \leq 1,5$ kV

Type	Connection	Suitable networks	U_c	I_{imp} (10/350 μ s)	I_n (8/20 μ s)	I_{max} (8/20 μ s)	Remote signalling	Ordering number
FLP-A50N VS/NPE	1+1	TT	255 V AC	50 kA	50 kA	100 kA	Yes	8595090535737
FLP-A100N VS/NPE	3+1	TT	255 V AC	100 kA	100 kA	100 kA	Yes	8595090535744

SPDs connected to LV power supply systems up to 1 000 V

Lightning current arresters and surge arresters (SPD Type 1 and 2), serial combination MOV+GDT

Very high-performance lightning current arresters for LV installations at the boundary of the LPZ 0 and LPZ 1 zones or higher. For protection in direct as well as indirect lightning strikes. For using in a variety of installations, for family houses, office and industrial buildings, or in sub-distribution boards of large buildings. **No leakage current. No follow-on current.**

FLP-B+C MAXI V(S)/...



- Pluggable module
- Visual fault signalling
- Module locking
- Optional remote fault signalling (S)
- $U_p \leq 1,5$ kV

Type	Connection	Suitable networks	U_c	I_{imp} (10/350 μ s)	I_n (8/20 μ s)	I_{max} (8/20 μ s)	Remote signalling	Ordering number
FLP-B+C MAXI V/1	1+0	TN	275 V AC	25 kA	30 kA	60 kA	No	8595090550914
FLP-B+C MAXI VS/1	1+0	TN	275 V AC	25 kA	30 kA	60 kA	Yes	8595090535331
FLP-B+C MAXI V/1+1	1+1	TT	275 V AC	25 kA	30 kA	60 kA	No	8595090550952
FLP-B+C MAXI VS/1+1	1+1	TT	275 V AC	25 kA	30 kA	60 kA	Yes	8595090537830
FLP-B+C MAXI V/2	2+0	TN-S	275 V AC	25 kA	30 kA	60 kA	No	8595090550921
FLP-B+C MAXI VS/2	2+0	TN-S	275 V AC	25 kA	30 kA	60 kA	Yes	8595090537847
FLP-B+C MAXI V/3	3+0	TN-C	275 V AC	25 kA	30 kA	60 kA	No	8595090550938
FLP-B+C MAXI VS/3	3+0	TN-C	275 V AC	25 kA	30 kA	60 kA	Yes	8595090535706
FLP-B+C MAXI V/3+1	3+1	TT	275 V AC	25 kA	30 kA	60 kA	No	8595090550969
FLP-B+C MAXI VS/3+1	3+1	TT	275 V AC	25 kA	30 kA	60 kA	Yes	8595090535720
FLP-B+C MAXI V/4	4+0	TN-S	275 V AC	25 kA	30 kA	60 kA	No	8595090550945
FLP-B+C MAXI VS/4	4+0	TN-S	275 V AC	25 kA	30 kA	60 kA	Yes	8595090535713
FLP-B+C MAXI150 V/1	1+0	TN	150 V AC	25 kA	30 kA	60 kA	No	8595090558347
FLP-B+C MAXI150 VS/1	1+0	TN	150 V AC	25 kA	30 kA	60 kA	Yes	8595090558354

Lightning current arresters and surge arresters (SPD Type 1 and 2), MOV based

For LV installations at the boundary of the LPZ 0 and LPZ 1 or higher. Protection against the impact of partial lightning strike currents, induced overvoltage in lightning strikes and against switching overvoltage. It is suitable for III and IV risk class buildings, in sub-distribution boards of large buildings or the protection of air conditioners or heating cables.

FLP-12,5 V/...



- Pluggable module
- Visual fault signalling
- Module locking
- Optional remote fault signalling (S)
- $U_p \leq 1,5$ kV

Type	Connection	Suitable networks	U_c	I_{imp} (10/350 μ s)	I_n (8/20 μ s)	I_{max} (8/20 μ s)	Remote signalling	Ordering number
FLP-12,5 V/1	1+0	TN	275 V AC	12,5 kA	30 kA	60 kA	No	8595090534211
FLP-12,5 V/1 S	1+0	TN	275 V AC	12,5 kA	30 kA	60 kA	Yes	8595090534228
FLP-12,5 V/1+1	1+1	TT	275 V AC	12,5 kA	30 kA	60 kA	No	8595090534235
FLP-12,5 V/1S+1	1+1	TT	275 V AC	12,5 kA	30 kA	60 kA	Yes	8595090534242
FLP-12,5 V/2	2+0	TN-S	275 V AC	12,5 kA	30 kA	60 kA	No	8595090538097
FLP-12,5 V/2 S	2+0	TN-S	275 V AC	12,5 kA	30 kA	60 kA	Yes	8595090551829
FLP-12,5 V/3	3+0	TN-C	275 V AC	12,5 kA	30 kA	60 kA	No	8595090534259
FLP-12,5 V/3 S	3+0	TN-C	275 V AC	12,5 kA	30 kA	60 kA	Yes	8595090534266
FLP-12,5 V/3+1	3+1	TT	275 V AC	12,5 kA	30 kA	60 kA	No	8595090534273
FLP-12,5 V/3S+1	3+1	TT	275 V AC	12,5 kA	30 kA	60 kA	Yes	8595090534280
FLP-12,5 V/4	4+0	TN-S	275 V AC	12,5 kA	30 kA	60 kA	No	8595090534297
FLP-12,5 V/4 S	4+0	TN-S	275 V AC	12,5 kA	30 kA	60 kA	Yes	8595090534303

Surge arresters (SPD Type 2), MOV based

For LV installations, especially to sub-distribution boards. Protection of installation and devices against impact of induced surge during a lightning strike or switching surges.

SLP-... V/... (S)



- Pluggable module
- Visual fault signalling
- Module locking
- Optional remote fault signalling (S)

Type	Connection	Suitable networks	U_c	I_n (8/20 μ s)	I_{max} (8/20 μ s)	Remote signalling	Ordering number
SLP-275 V/1	1+0	TN	275 V AC	20 kA	40 kA	No	8595090516170
SLP-275 V/1 S	1+0	TN	275 V AC	20 kA	40 kA	Yes	8595090516187
SLP-275 V/1+1	1+1	TT	275 V AC	20 kA	40 kA	No	8595090519485
SLP-275 V/1S+1	1+1	TT	275 V AC	20 kA	40 kA	Yes	8595090524915
SLP-275 V/2	2+0	TN-S	275 V AC	20 kA	40 kA	No	8595090516194
SLP-275 V/2 S	2+0	TN-S	275 V AC	20 kA	40 kA	Yes	8595090551836
SLP-275 V/3	3+0	TN-C	275 V AC	20 kA	40 kA	No	8595090517603
SLP-275 V/3 S	3+0	TN-C	275 V AC	20 kA	40 kA	Yes	8595090517610
SLP-275 V/3+1	3+1	TT	275 V AC	20 kA	40 kA	No	8595090519461
SLP-275 V/3S+1	3+1	TT	275 V AC	20 kA	40 kA	Yes	8595090520023
SLP-275 V/4	4+0	TN-S	275 V AC	20 kA	40 kA	No	8595090517221
SLP-275 V/4 S	4+0	TN-S	275 V AC	20 kA	40 kA	Yes	8595090517634
SLP-075 V/1	1+0	TN	75 V AC	15 kA	40 kA	No	8595090518150
SLP-075 V/1 S	1+0	TN	75 V AC	15 kA	40 kA	Yes	8595090518235
SLP-150 V/1	1+0	TN	150 V AC	15 kA	40 kA	No	8595090551850
SLP-150 V/1 S	1+0	TN	150 V AC	15 kA	40 kA	Yes	8595090551867
SLP-385 V/1	1+0	TN	385 V AC	20 kA	40 kA	No	8595090519553
SLP-385 V/1 S	1+0	TN	385 V AC	20 kA	40 kA	Yes	8595090527718
SLP-440 V/1	1+0	TN	440 V AC	20 kA	40 kA	No	8595090518174
SLP-440 V/1 S	1+0	TN	440 V AC	20 kA	40 kA	Yes	8595090518259
SLP-600 V/1	1+0	TN	760 V AC	15 kA	40 kA	No	8595090533016
SLP-600 V/1 S	1+0	TN	760 V AC	15 kA	40 kA	Yes	8595090533023

Surge arresters (SPD Type 2), serial combination MOV+GDT

For protection of installations and devices against the impact of induced overvoltage in lightning strikes in areas with more frequent storms and against switching overvoltage. Suitable for diesel-powered networks and networks with fluctuating voltages. For protection of measurement circuits as the first level of protection. It is also suitable for installations in communication (I&C) circuits at the boundary of the LPZ 0 and LPZ 1. **No leakage current. No follow-on current.**

SLP-... VB/... (S)



- Pluggable module
- Visual fault signalling
- Module locking
- Optional remote fault signalling (S)

Type	Connection	Suitable networks	U_c	I_n (8/20 μ s)	I_{max} (8/20 μ s)	Remote signalling	Ordering number
SLP-075 VB/1	1+0	TN	75 V AC	15 kA	25 kA	No	8595090521556
SLP-075 VB/1 S	1+0	TN	75 V AC	15 kA	25 kA	Yes	8595090521563
SLP-130 VB/1	1+0	TN	130 V AC	20 kA	25 kA	No	8595090521822
SLP-130 VB/1 S	1+0	TN	130 V AC	20 kA	25 kA	Yes	8595090529965
SLP-275 VB/1	1+0	TN	275 V AC	20 kA	25 kA	No	8595090519447
SLP-275 VB/1 S	1+0	TN	275 V AC	20 kA	25 kA	Yes	8595090519454
SLP-275 VB/3+1	3+1	TN-S, TT	275 V AC	20 kA	25 kA	No	8595090533108
SLP-275 VB/3S+1	3+1	TN-S, TT	275 V AC	20 kA	25 kA	Yes	8595090533115

SPDs connected to LV power supply systems up to 1 000 V

Surge protections (SPD Type 3) on the DIN rail, parallel connection

A combination of varistor surge protection and an encapsulated spark gap connected in the 1+1 (3+1) mode. For LV installations at the boundary of the LPZ 2 and LPZ 3 zones. For protection installations and devices against the impact of induced overvoltage in lightning strikes and against switching overvoltage. Location as close as possible to the protected device.

DA-275 V/... (S)



- Pluggable module
- Visual fault signalling
- Module locking
- Optional remote fault signalling (S)
- $U_p \leq 1,5$ kV

Type	Connection	Suitable networks	U_c	I_n (8/20 μ s)	U_{oc}	Remote signalling	Ordering number
DA-275 V/1+1	1+1	TN-S, TT	275 V AC	5 kA	10 kV	No	8595090518723
DA-275 V/1S+1	1+1	TN-S, TT	275 V AC	5 kA	10 kV	Yes	8595090519751
DA-275 V/3+1	3+1	TN-S, TT	275 V AC	5 kA	10 kV	No	8595090518488
DA-275 V/3S+1	3+1	TN-S, TT	275 V AC	5 kA	10 kV	Yes	8595090518495

Surge protections (SPD Type 3) on the DIN rail, serial connection

A surge arrester for universal use to protect all types of LV electrical and electronic devices against transient overvoltage. Location as close as possible to the protected device.

DA-275-DJ25 (S), DA-... DJ



- Symmetrical internal connection
- Visual fault signalling
- Optional remote fault signalling (S)
- $U_p \leq 1,5$ kV

Type	Connection	Suitable networks	U_c	I_L	I_n (L+N-PE) (8/20 μ s)	U_{oc} (L+N-PE)	Remote signalling	Ordering number
DA-275-DJ25	Symmetric	TN-S, TT	275 V AC	25 A	5 kA	10 kV	No	8595090557708
DA-275-DJ25-S	Symmetric	TN-S, TT	275 V AC	25 A	5 kA	10 kV	Yes	8595090557715
DA-075 DJ	Symmetric	TN-S, TT	75 V AC	16 A	4 kA	8 kV	No	8595090533191
DA-130 DJ	Symmetric	TN-S, TT	130 V AC	16 A	5 kA	10 kV	No	8595090521891

Surge protections (SPD Type 3) for additional mounting

Surge arresters for additional mounting to devices, machines, equipment, etc. For protection of all types LV electrical and electronic devices against transient overvoltage. Location as close as possible to the protected device.

CZ-275-A, DA-275-...



- Acoustic or remote status signalling
- $U_p \leq 1,5$ kV

Type	Connection	Suitable networks	U_c	I_n (L+N-PE) (8/20 μ s)	U_{oc} (L+N-PE)	Status signalling	Ordering number
CZ-275-A	1+1	TN, TT	275 V AC	3 kA	6 kV	Acoustic	8595090559573
DA-275 CZS	1+1	TN, TT	275 V AC	3 kA	6 kV	Remote	8595090519164
DA-275-A	Symmetric	TN, TT	275 V AC	2 kA	4 kV	Acoustic	8595090559580
DA-275-S	Symmetric	TN, TT	275 V AC	2 kA	4 kV	Remote	8595090559597

Surge protections (SPD Type 3) on the DIN rail, with RFI filter

A surge arrester with an integrated RFI filter to protect the supply of control systems such as I&C, electronic security and fire alarm systems, etc., against transient overvoltage and RF disturbance. Variants "I" with remote fault signalling by interruption of power supply. Location as close as possible to the protected device.

DA-275-DF...(-S), DA-... DF ... (S)



- Visual fault signalling
- Optional remote fault signalling (S)
- Filter attenuation range ca. 150 kHz ÷ 30 MHz
- $U_p \leq 1,5$ kV

Type	Connection	Suitable networks	U_c	I_L	I_n (L+N-PE) (8/20 μ s)	U_{oc} (L+N-PE)	Remote signalling	Ordering number
DA-275-DF2	Symmetric	TN, TT	275 V AC	2 A	5 kA	10 kV	No	8595090557159
DA-275-DF2-S	Symmetric	TN, TT	275 V AC	2 A	5 kA	10 kV	Yes	8595090557166
DA-275-DF6	Symmetric	TN, TT	275 V AC	6 A	5 kA	10 kV	No	8595090557173
DA-275-DF6-S	Symmetric	TN, TT	275 V AC	6 A	5 kA	10 kV	Yes	8595090557180
DA-275-DF10	Symmetric	TN, TT	275 V AC	10 A	5 kA	10 kV	No	8595090557197
DA-275-DF10-S	Symmetric	TN, TT	275 V AC	10 A	5 kA	10 kV	Yes	8595090557203
DA-275-DF16	Symmetric	TN, TT	275 V AC	16 A	5 kA	10 kV	No	8595090557210
DA-275-DF16-S	Symmetric	TN, TT	275 V AC	16 A	5 kA	10 kV	Yes	8595090557227
DA-275 DF 25	Symmetric	TN, TT	275 V AC	25 A	5 kA	10 kV	No	8595090537328
DA-400 DF 16	Symmetric	TN, TT	440 V AC	16 A	5 kA	10 kV	No	8595090515074
DA-400 DF 16 S	Symmetric	TN, TT	440 V AC	16 A	5 kA	10 kV	Yes	8595090525660
DA-275 DFI 1	Symmetric	TN, TT	275 V AC	1 A	1,5 kA	3 kV	Interruption	8595090512059
DA-275-DFI6	Symmetric	TN, TT	275 V AC	6 A	5 kA	10 kV	Interruption	8595090557234
DA-275-DFI10	Symmetric	TN, TT	275 V AC	10 A	5 kA	10 kV	Interruption	8595090557241
DA-275-DFI16	Symmetric	TN, TT	275 V AC	16 A	5 kA	10 kV	Interruption	8595090557258
DA-275 BFG	Symetrické	TN, TT	275 V AC	16 A	5 kA	10 kV	No	8595090506294

Multiple sockets with surge protection (SPD Type 3) into 19" RACK

Surge protection SPD type 3 for protection of information technology in 19" RACKs with visual fault signaling. Variants with switch or RFI filter. Earth pin socket version. Location as close as possible to the protected device.

RACK-PROTECTOR-...-1U



- Mounting height 1U
- Power supply cord 3 m, CEE 7/7 plug
- Visual fault signalling
- $U_n = 230$ V AC, $I_L = 16$ A

Type	Sockets	Switch	RFI filter	I_n (8/20 μ s)	U_{oc}	U_p	Ordering number
RACK-PROTECTOR-F6-1U	6	No	Yes	5 kA	10 kV	1,5 kV	8595090558743
RACK-PROTECTOR-VF5-1U	5	Yes	Yes	5 kA	10 kV	1,5 kV	8595090558750
RACK-PROTECTOR-VX7-1U	7	Yes	No	5 kA	10 kV	1,5 kV	8595090558736
RACK-PROTECTOR-X8-1U	8	No	No	5 kA	10 kV	1,5 kV	8595090558729
RACK-PROTECTOR-EURO-X12-1U	12 EURO	No	No	3 kA	6 kV	1,6 kV	8595090559610

SPDs connected to LV power supply systems up to 1 000 V

Coordination impedance RTO-...

Coupling impedance to secure proper coordination of a SPD if the minimum distance between a Type 1 SPD and Type 2 SPD, which exceeds 10 m, is not maintained, or a Type 2 and Type 3 SPD, which exceeds 5 m.



- Surge separating inductors

Type	U_c	I_L	Resistance	Inductance	Power loss at I_L	Ordering number
RTO-16	500 V AC	16 A	5 m Ω	10 μ H	1,28 W	8595090514329
RTO-35	500 V AC	35 A	2,5 m Ω	10 μ H	3 W	8595090514336
RTO-63	500 V AC	63 A	2 m Ω	10 μ H	8 W	8595090514343

Surge protection (SPD Type 3 and Type 2 and 3) for LED lights

SPDs mainly for drivers of LED lights. Installation close to protected equipment into LV power circuits. Also for equipments in external part of structure with low or high exposure level (according IEEE C62.41.2). Fault signaling by supply interruption.

DA-320-LED



- For equipment in external part of building with low exposure level
- $U_p \leq 1,5$ kV

SP-T2+T3-320/Y-CLT-LED



- For equipment in external part of building with high exposure level
- $U_p \leq 1,5$ kV

Type	SPD Type	Location	U_c	I_L	I_n (8/20 μ s)	U_{oc} (L+N-PE)	Fault signalling	Ordering number
DA-320-LED	3	C low	320 V AC	5 A	3 kA	6 kV	Interruption	8595090558767
SP-T2+T3-320/Y-CLT-LED	2 a 3	C high	320 V AC	10 A	5 kA	10 kV	Interruption	8595090560449

Sales and technical support:

SALTEK TRADE s.r.o.

Vodňanská 1419/226

198 00 Praha 9 - Kyje

Czech Republic

Phone: +420 272 942 470

Fax: +420 267 913 411

E-mail: trade@saltek.cz

www.saltek.eu/en

Manufacture and headquarter:

SALTEK s.r.o.

Dražďanská 85

400 07 Ústí nad Labem

Czech Republic

Phone: +420 475 655 511

Fax: +420 475 622 213

E-mail: info@saltek.cz

www.saltek.eu

Distributor: